

Disclaimer

About This Guide

Unboxing

Check Before Installation

In the Solarbank Box

In the Expansion Battery Box

Optional Accessories

Product Overview

At a Glance

Button Controls

Screen Guide

Pre-Installation

Determine the Stacking Order

Select an Installation Site

Tools Not Supplied

Installation

Precautions

Step 1. Remove Rubber Plugs

Step 2. Install Expansion Batteries

Step 3. Install the Solarbank

Step 4. Install the Interlocking Kit

Electrical Connections

Precautions

Connect to the Ground

Connect to PV Modules

Connect to the Grid

Connect to Your Device

(Optional) Install the Smart Meter

(Optional) Install the Smart Plug

(Optional) Connect the Communication Cables

Device Setup

Power On / Off

Confirm Networking Status

Use the Anker App

Download the Anker App

Sign Up / Sign In

Add Device

Select Scene

Initialization Settings

Perform Italy Self-Test (Italy only)

Customize Power Mode

Specifications

Anker SOLIX Solarbank 4 E5000 Pro

Anker SOLIX BP5000 Expansion Battery

Disclaimer

Please read and understand all safety instructions, installation guide, and other accompanied documents before installing or using the product. Failure to follow the instructions may result in electric shock, equipment damage, or personal injury. Please follow the instructions and install this equipment with caution for your safety and the normal operation of the equipment. The manufacturer is not liable for damage, injury, or loss resulting from incorrect installation, unauthorised modification, misuse, operation in unsuitable environments, or failure to observe safety precautions.

About This Guide

This guide describes **Anker SOLIX Solarbank 4 E5000 Pro** in terms of unboxing, product overview, installation, electrical connections, button and light explanation, customer, and safety guidelines.

- One **Anker SOLIX Solarbank 4 E5000 Pro** can support up to five **Anker SOLIX Expansion Batteries**.
- **Anker SOLIX Solarbank 4 E5000 Pro** can be used with **Anker SOLIX Expansion Battery BP5000 / BP2700 / BP1600**.
- **Anker SOLIX Solarbank 4 E5000 Pro** can be used with Anker SOLIX Smart Meter, Anker SOLIX Smart Plug and some third-party devices, which is updated periodically.

Unboxing

Check Before Installation

Inspect the Outer Packaging

Before unpacking the equipment, check the outer packaging for damage, such as holes and cracks, and review the equipment model number. If any damage is found or the model is not what you requested, do not unpack the equipment and contact Anker customer service as soon as possible.

Verify Deliverables

After unpacking the equipment, check that the deliverables are intact and complete, and free from any obvious damage. If any item is missing or damaged, contact Anker Solix customer service.

In the Solarbank Box



Anker SOLIX
Solarbank 4
E5000 Pro

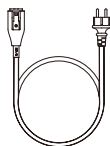

AC Cable (3m)

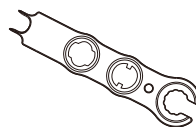

Wrench for
Removing PV
Connectors



Documents

Wall Mount Kit



Wall Mount Fitting
for Solarbank x2

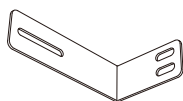

Wall Mount Fitting
for Expansion
Battery x2

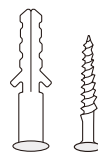

Expansion Screw
(M6 50 mm) x4



Screw
(M5 10 mm) x4

Spare Parts

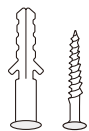

Expansion Screw
(M6 50 mm) x2

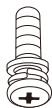

Screw
(M5 10 mm) x2

In the Expansion Battery Box

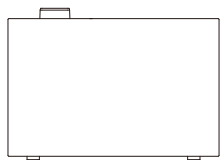

Anker SOLIX
BP5000 Expansion
Battery



Documents

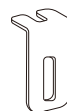

Fixed Bracket x2



Screw
(M5 10 mm) x2

Interlocking Kit

Wall Mount Kit

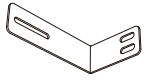

Wall Mount Fitting for Expansion Battery×2



Expansion Screw (M6 50 mm) ×2



Screw (M5 10 mm) ×2



Expansion Screw (M6 50 mm) ×2

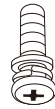

Screw (M5 10 mm) ×2

Optional Accessories

The following accessories can be ordered separately.

Connection and Installation Accessories

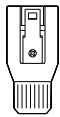

AC Connector



COM Connector

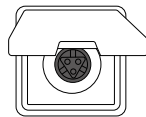

Wieland Socket

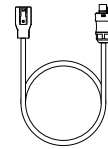

AC Cable with Wieland Plug



3-in-1 PV Adapter Cable

Compatible Devices

Anker SOLIX Smart Meter



Anker SOLIX Smart Meter

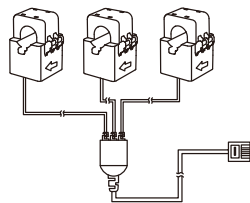

CT Cable Assembly

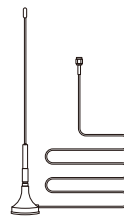

Extension Antenna

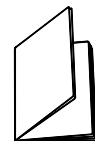

Documents

Anker SOLIX Smart Meter Gen 2

Single-Phase

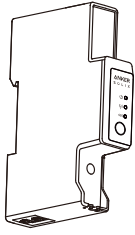

Anker SOLIX Smart
Meter Gen 2
(Single-Phase)

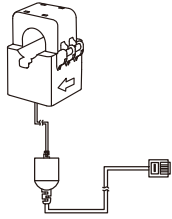

63A Triple CT
Cable Assembly

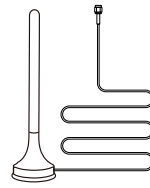

Extension
Antenna



Documents

Three-Phase

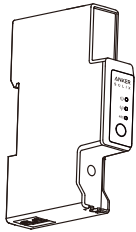

Anker SOLIX
BP5000 Battery

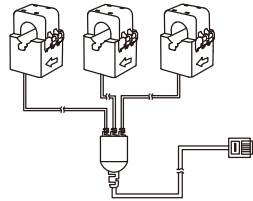

Documents

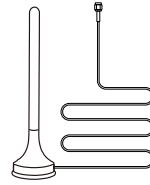

Extension
Antenna

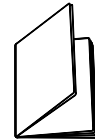

Documents

Optional Accessories

*If you purchase a three-phase meter and need to monitor a third-party PV system or energy storage system, you can purchase an additional CT cable assembly separately.

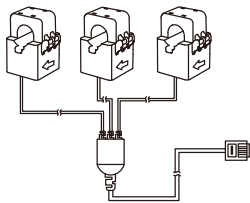

Triple CT Cable
Assembly

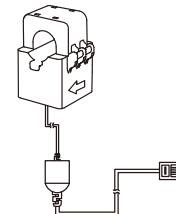

Single CT Cable
Assembly

Anker SOLIX Smart Plug (Gen 2)

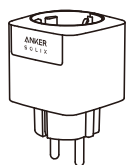

Anker SOLIX Smart Plug (Gen 2)

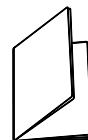

Documents

Product Overview

At a Glance

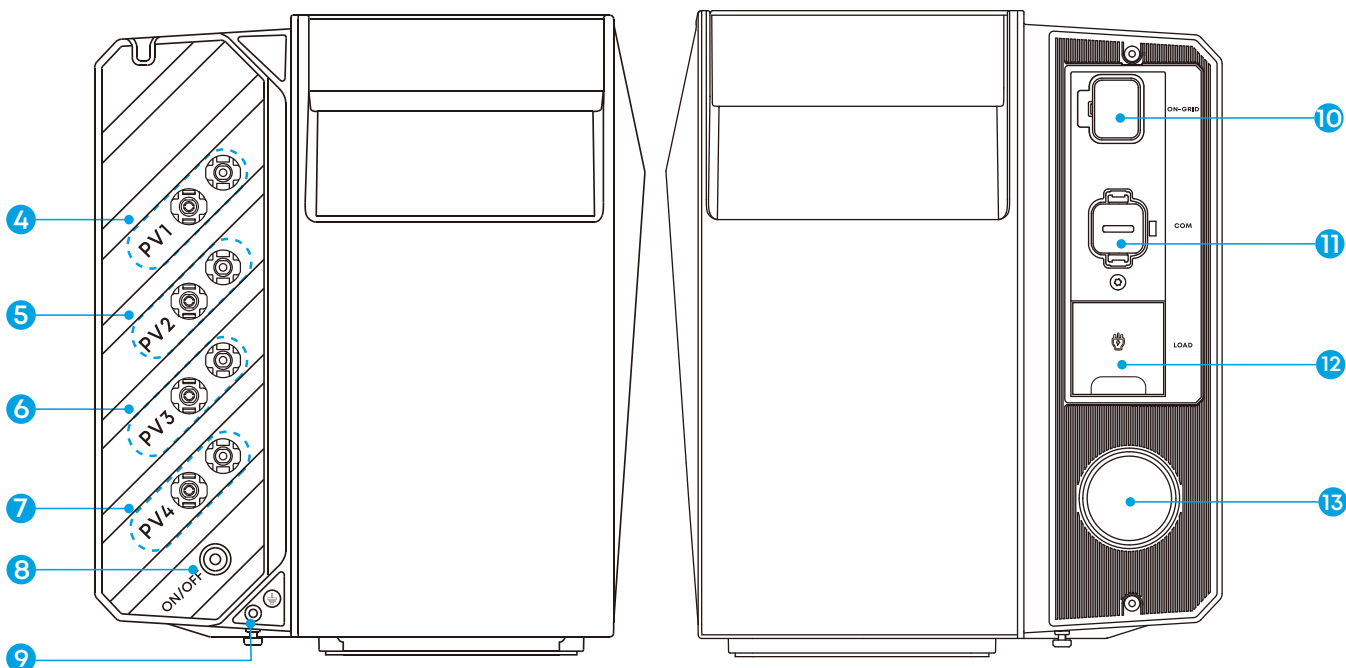
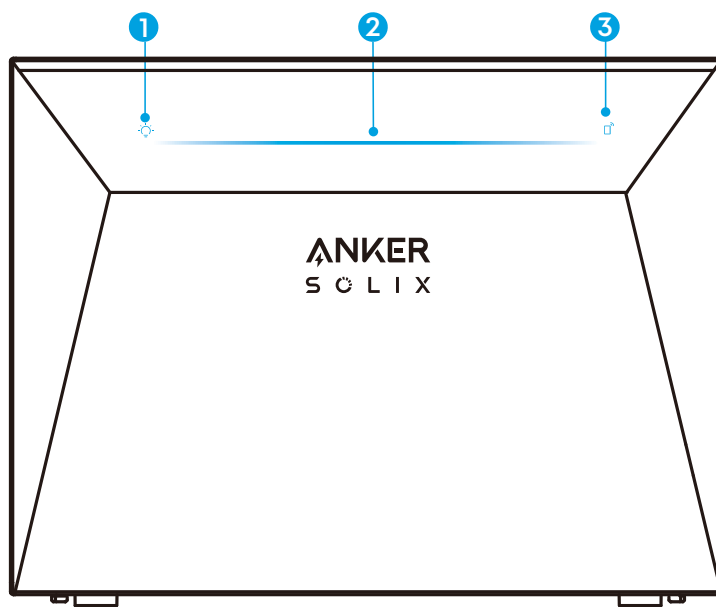

1. Screen On / Off Button
2. Working Status LED
3. IoT Button
4. PV Connector Ports for PV Input 1
5. PV Connector Ports for PV Input 2
6. PV Connector Ports for PV Input 3
7. PV Connector Ports for PV Input 4
8. Power Button
9. Ground Screw Hole
10. On-Grid Port
11. Communication Port
12. Load Port
13. Pressure Relief Valve (This valve is a safety device. Do not operate or damage it.)

Button Controls

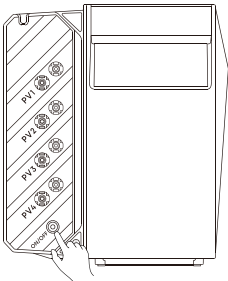
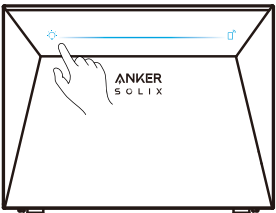
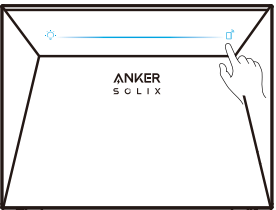
Button	Action	Function
	Press for 2 seconds.	Turn Solarbank on / off.
	Press once.	Turn the screen on or off.
	Press once. Press for 2 seconds. Press for 7 seconds.	Enable Internet connection. Disable Internet connection. Reset Bluetooth and Wi-Fi.

Screen Guide



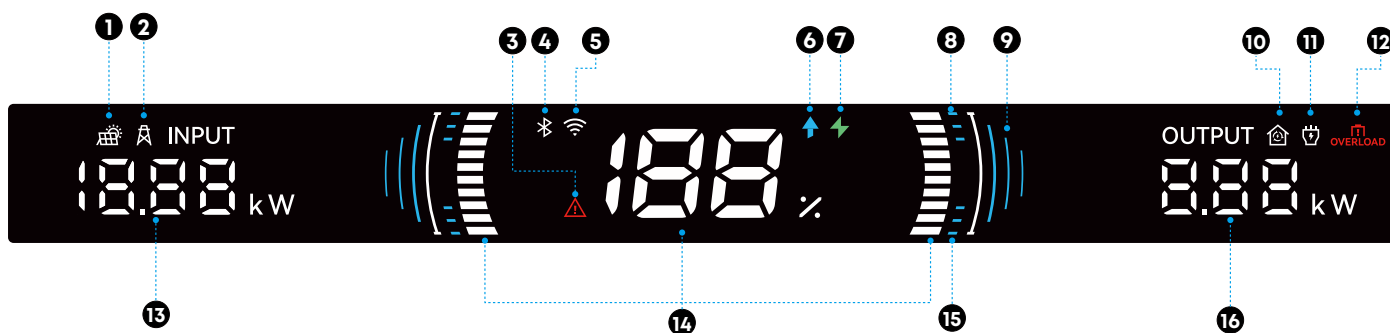







The display may vary by firmware version.



Indicator	Description
1	Input from PV Panels Displays the power drawn from the PV Panels.
2	Input from Grid Displays the power drawn from the grid.
3	General Fault Alert Indicates a fault. Check the Anker app for details.
4	Bluetooth Status Flashing: Connecting to Bluetooth. Solid: Connected to Bluetooth.
5	Wi-Fi Status Flashing: Connecting to Wi-Fi. Solid: Connected to Wi-Fi.
6	Charging Status Indicates that the battery is charging.
7	Discharging Status Indicates that the battery is discharging.
8	Charge Upper Limit Displays the configured upper limit for charging.
9	Smart Mode Indicates that smart mode is enabled.
10	Output to Grid Indicates power export to the grid.
11	Output to Loads Indicates power supply to home loads.
12	Overload Alert Disconnect some devices to reduce the load.

- 13 **Total Input Power**
Displays the total power currently flowing into the system.
- 14 **Battery SOC**
Displays the current battery state of charge.
- 15 **Discharge Lower Limit**
Displays the configured lower limit for discharging.
- 16 **Total Output Power**
Displays the total power delivered to connected loads.

LED Guide

LED	Status
	Powered On The blue LED illuminates from both ends toward the center.
	Powered Off LED fades from both ends toward the center.
	Connecting to the Network LED flashes.
	Connected to the Network LED turns solid.
	Charging LED spreads outward from the center.
	Discharging LED turns solid.
	Switching to Smart Mode Blue LED changes to a blue-to-green gradient.
	Switching to Non-Smart Mode The blue-to-green gradient LED turns blue.
	Firmware Updating or Self-Testing LED runs from one end to the other.
	Malfunction LED flashes red. Check the Anker app for details.

Pre-Installation

Determine the Stacking Order

When different models of expansion batteries are used together, stack them in the order BP1600 to BP2700 to BP5000 from bottom to top for maximum charging capacity.

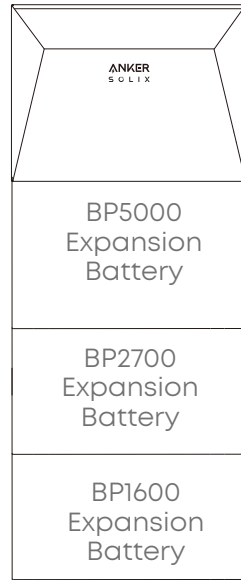

Select an Installation Site

Equipment Dimensions

Solarbank: 460 (W) × 305 (D) × 355 (H) mm

Expansion Battery: 460 (W) × 254 (D) × 332.5 (H) mm

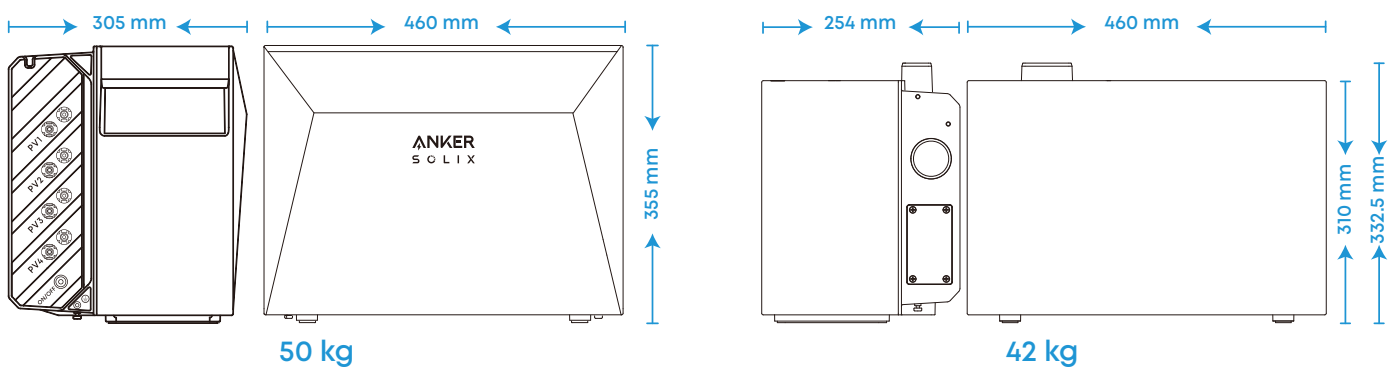

Environmental Requirements

- Do not place the modules near an area exposed to direct sunlight, fire, or explosive materials.
- Ensure the site is protected from potential hazards such as floods.
- The maximum operating altitude is 4,000 m.

- Within Wi-Fi coverage
- Ensure the AC Cable (3m) can reach the Solarbank
- Ensure easy connection to PV panels
- Maintain clearance from wall to bottom unit:
 - BP5000: 64–84 mm
 - BP2700 / BP1600: 85–105 mm

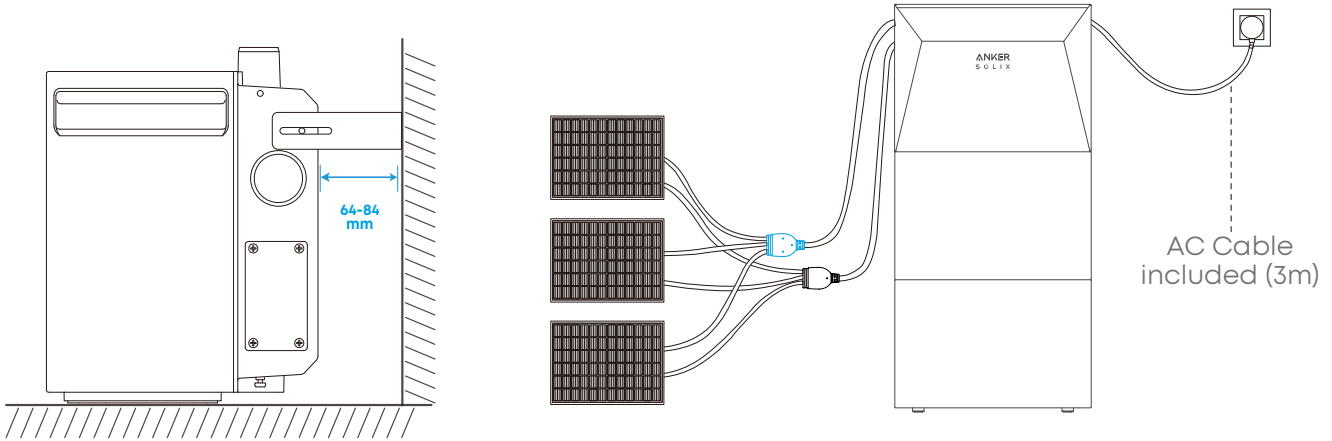

Tools Not Supplied

The following tools are not included in this package. Please make sure they are ready before installation and electrical connections.



Pen

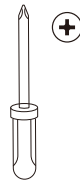

Phillips Screwdriver
(PH1 and PH2)



Insulating Gloves

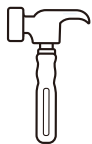

Hammer

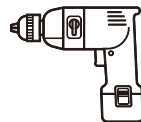

Power Drill
(Drill Bit: 8 mm)

Installation

Precautions

- The following steps describe how to install one Solarbank and two expansion batteries (BP5000) as an example.
- Ensure Solarbank is off during installation.

Step 1. Remove Rubber Plugs

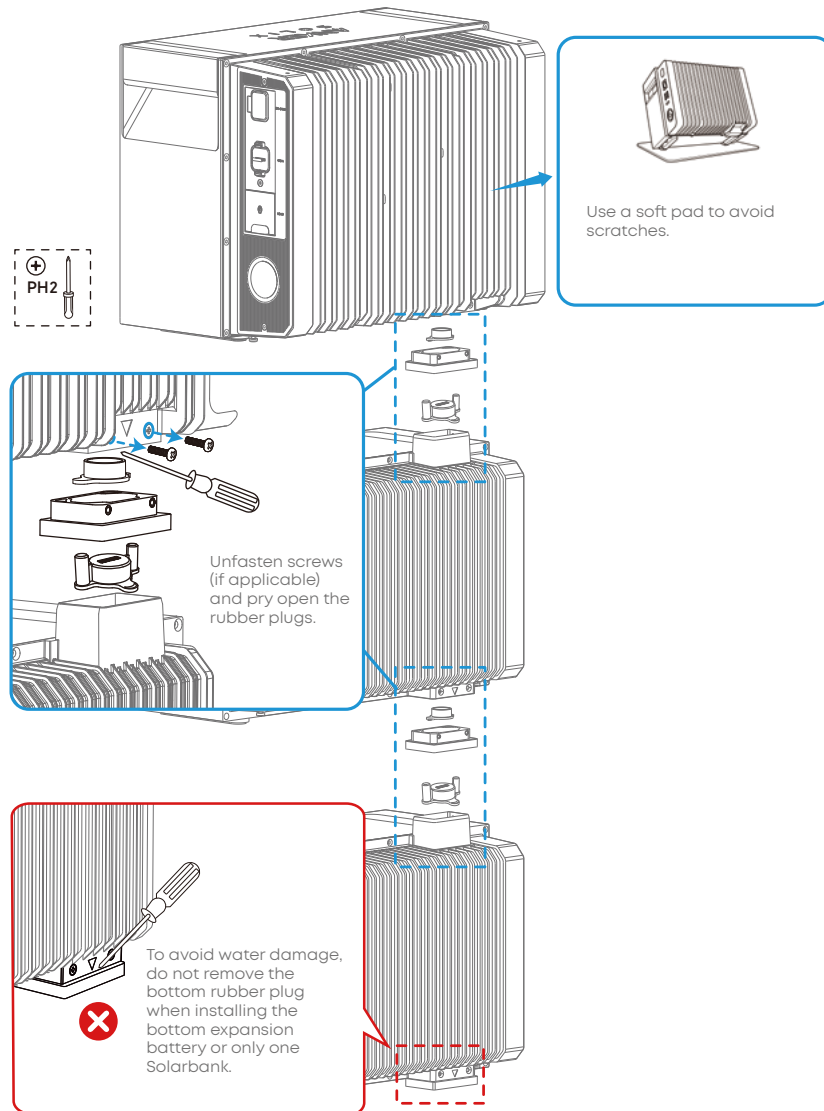

Step 2. Install Expansion Batteries



Anker SOLIX Solarbank 4 E5000 Pro is compatible with Expansion Battery BP5000 / BP2700 / BP1600. For wall-mounting configurations by different Expansion Battery models and quantities, refer to the table and illustrations below.

Models of Expansion Batteries	Application of Wall Mount Fittings
Only BP5000	Attach the wall mount fittings¹ to every expansion battery.
Only BP2700 or BP1600	Attach the wall mount fittings² to the first expansion battery under Solarbank. Extra fittings are not needed for other expansion batteries.
BP5000+ BP2700 or BP1600	Attach the wall mount fittings¹ to every BP5000 Expansion Battery. Attach the wall mount fittings² to the first expansion battery under BP5000 Expansion Battery.

¹ Fittings included with BP5000 Expansion Battery

² Fittings included with Solarbank 4 E5000 Pro



Fittings in **Blue**: included with BP5000 Expansion Battery

Fittings in **Orange**: included with Solarbank 4 E5000 Pro

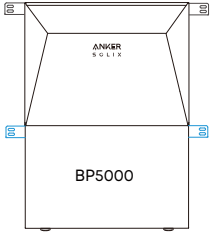
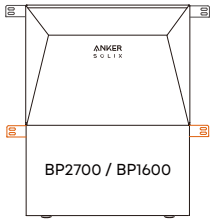
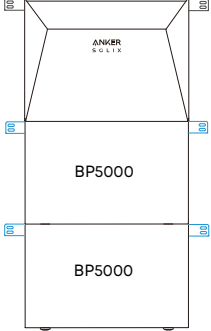
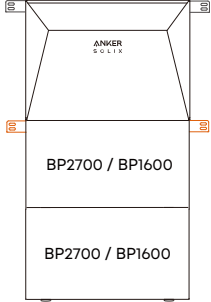
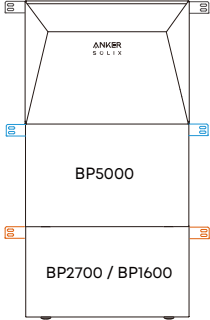
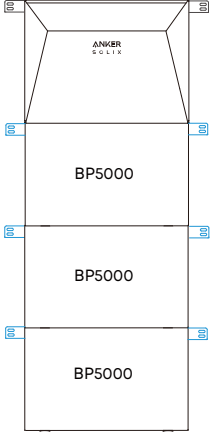
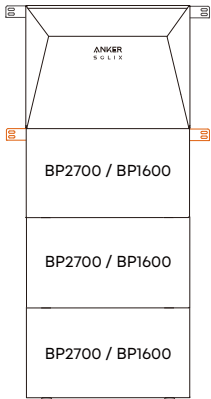
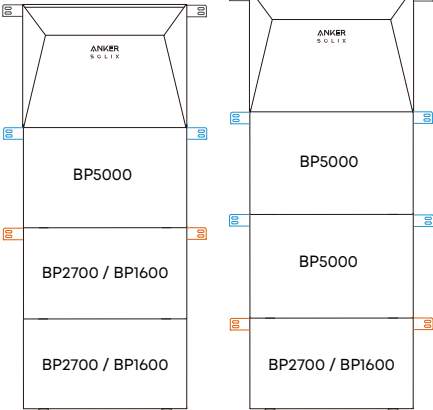
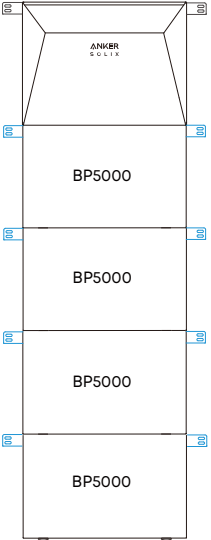
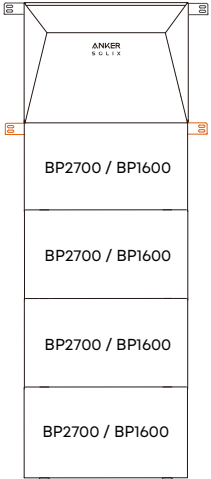
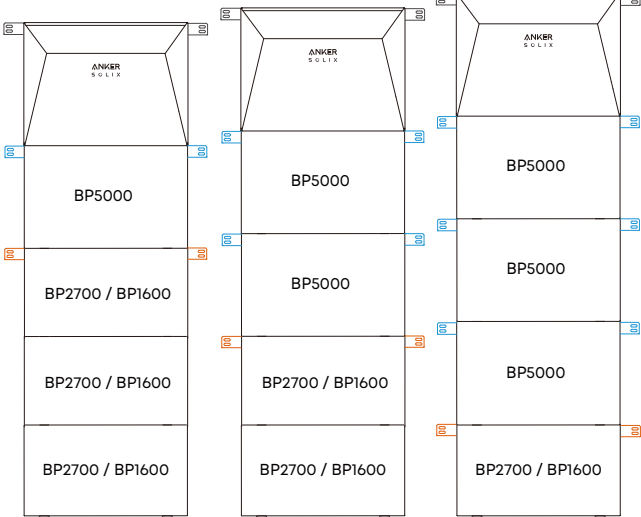
No. Of Expansion Batteries	Only BP5000	Only BP2700 or BP1600	BP5000+ BP2700 orBP1600
1			
2			
3			
4			

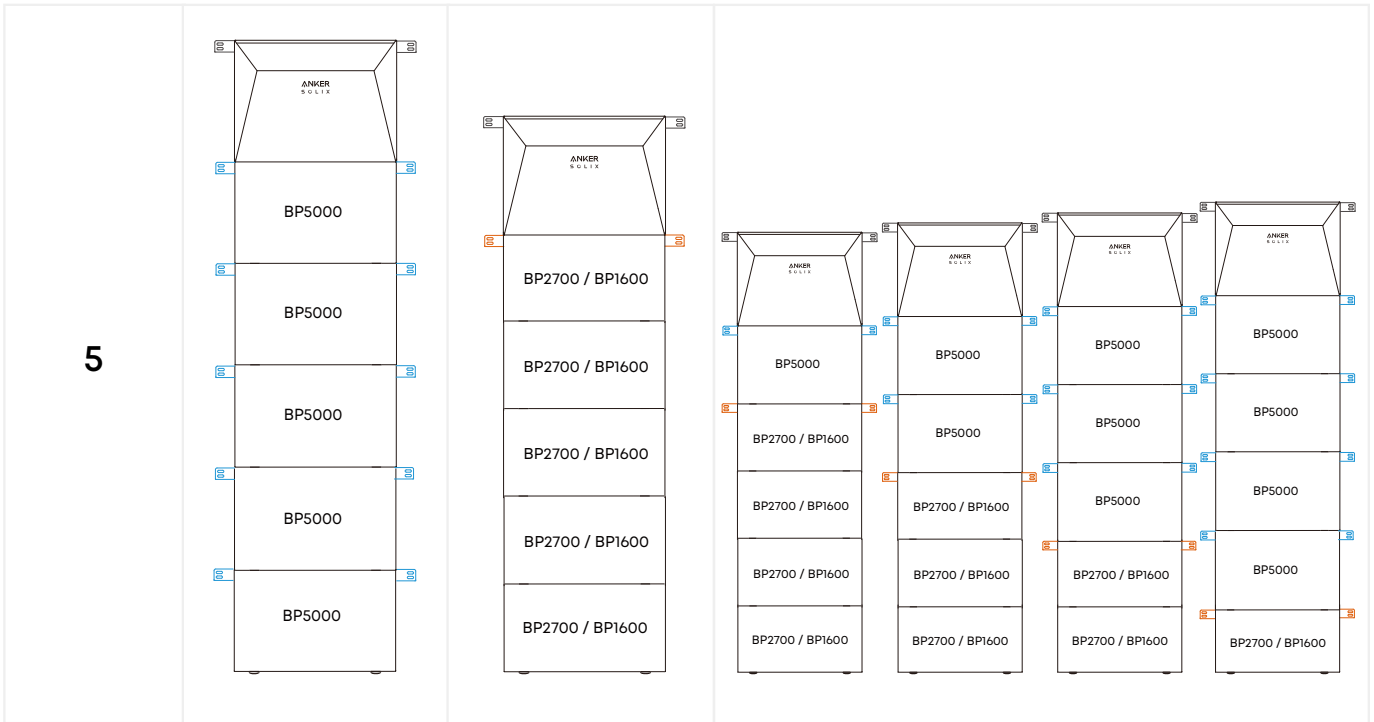

To install Expansion Batteries

- Stack the expansion batteries in sequence by inserting the two corresponding ports into each other.
- After stacking each expansion battery, attach the wall mount fittings to both sides of the unit to secure it.
 1. Partially tighten the short screw.
 2. Mark a pilot hole.
 3. Rotate the fitting down.
 4. Drill the marked hole.
 5. Insert the anchor.
 6. Rotate the fitting back up.
 7. Tighten the long screw.
 8. Tighten the short screw.

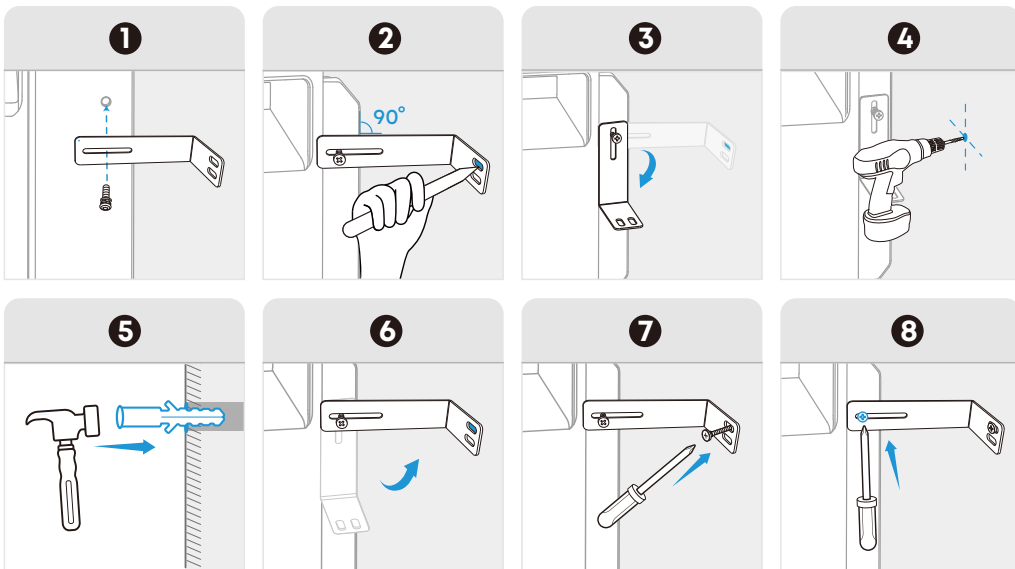
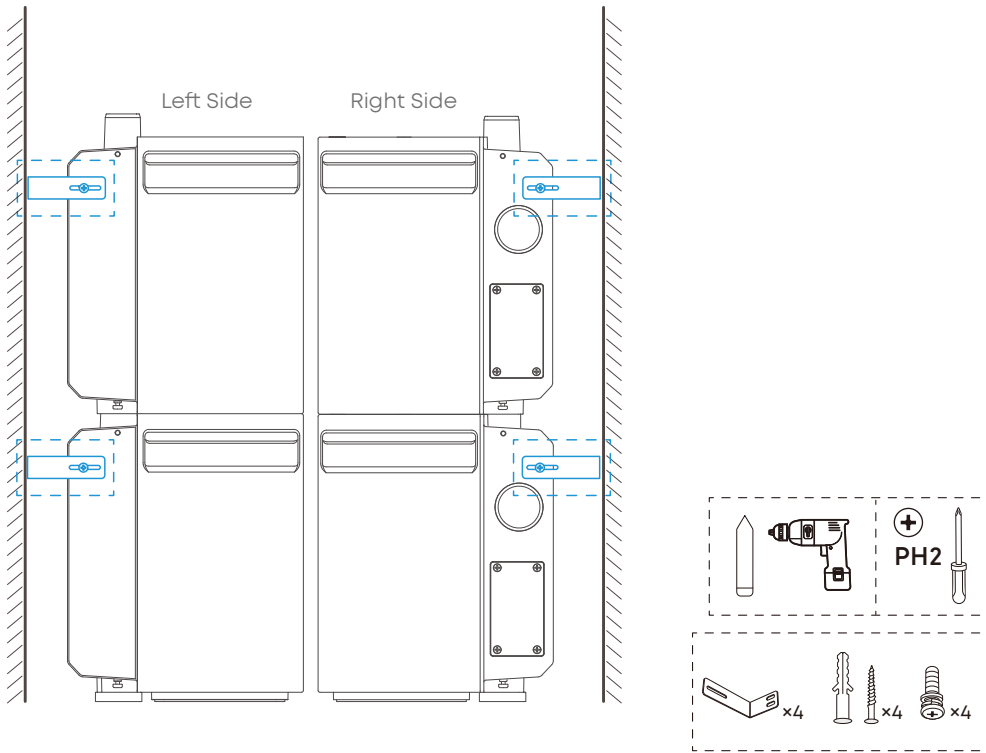

Step 3. Install the Solarbank

- Stack Solarbank at the top by inserting the two corresponding ports into each other.
- Attach the wall mount fittings to both sides of the Solarbank.

1. Partially tighten the short screw.
2. Mark a pilot hole.
3. Rotate the fitting outwards.
4. Drill the marked hole.
5. Insert the anchor.
6. Rotate the fitting back.
7. Tighten the long screw.
8. Tighten the short screw.

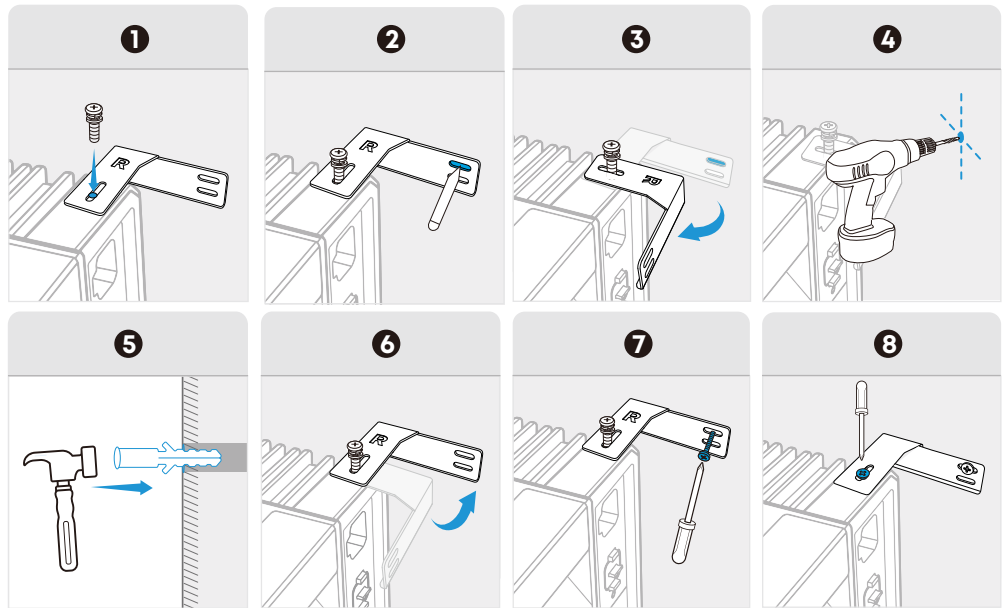
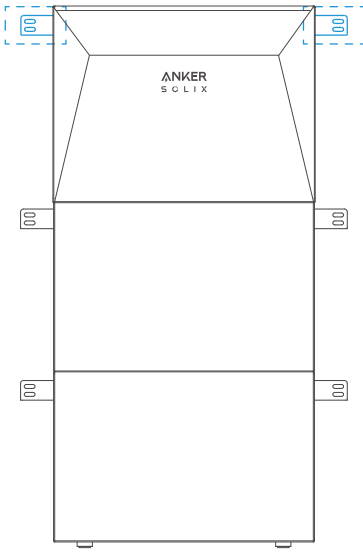

Step 4. Install the Interlocking Kit

1. Snap a fixed bracket in place.
2. Tighten the screw.

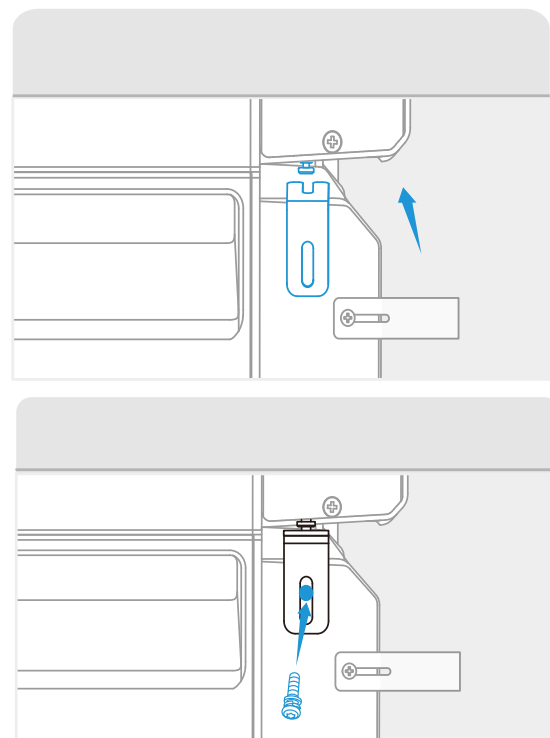
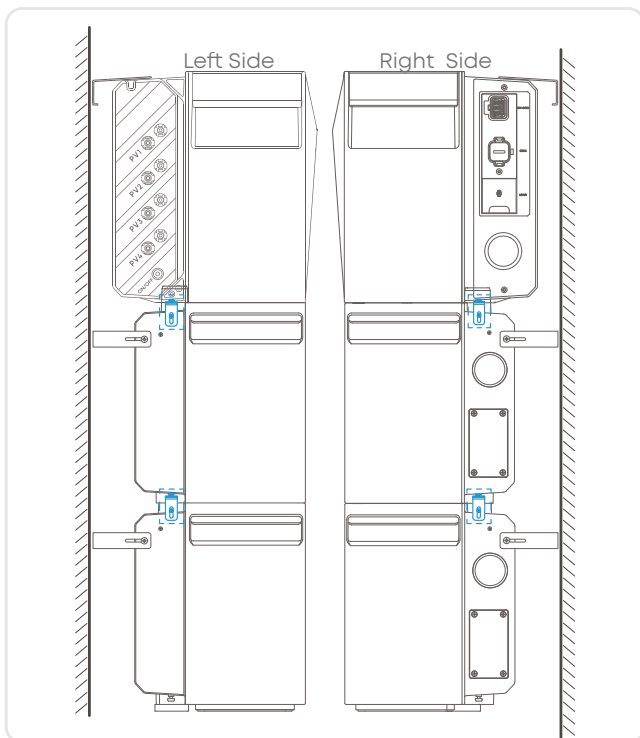

Electrical Connections

Precautions

- Ensure Solarbank is off during wiring.
- Do not use or turn on Solarbank after it has come into contact with water.

Connect to the Ground

Solarbank must be connected to the external ground point, otherwise there is a risk of electric shock.

The following tools and supplies are not included in the package. Ensure that you have them ready before proceeding with the electrical connections.

Required supplies	Specifications
GND cable	2.5 mm ² , yellow/green
Ring terminal	Suitable for the 1 mm ² GND cable and the M5 screw
Heat shrink tubing	Caliber: 8 mm Length: 25 mm
Heat gun	/
Phillips screwdriver	PH2

To connect Solarbank to the external ground point, follow the steps below.

1. Strip the insulation layer of the GND cable.
2. Insert a heat shrink tubing and a ring terminal into the GND cable.
3. Crimp the ring terminal onto the GND cable using a crimper.
4. Wrap the wire crimping area with the heat shrink tubing using a heat gun.
5. Loosen the pre-installed screw and use it to secure the GND cable.

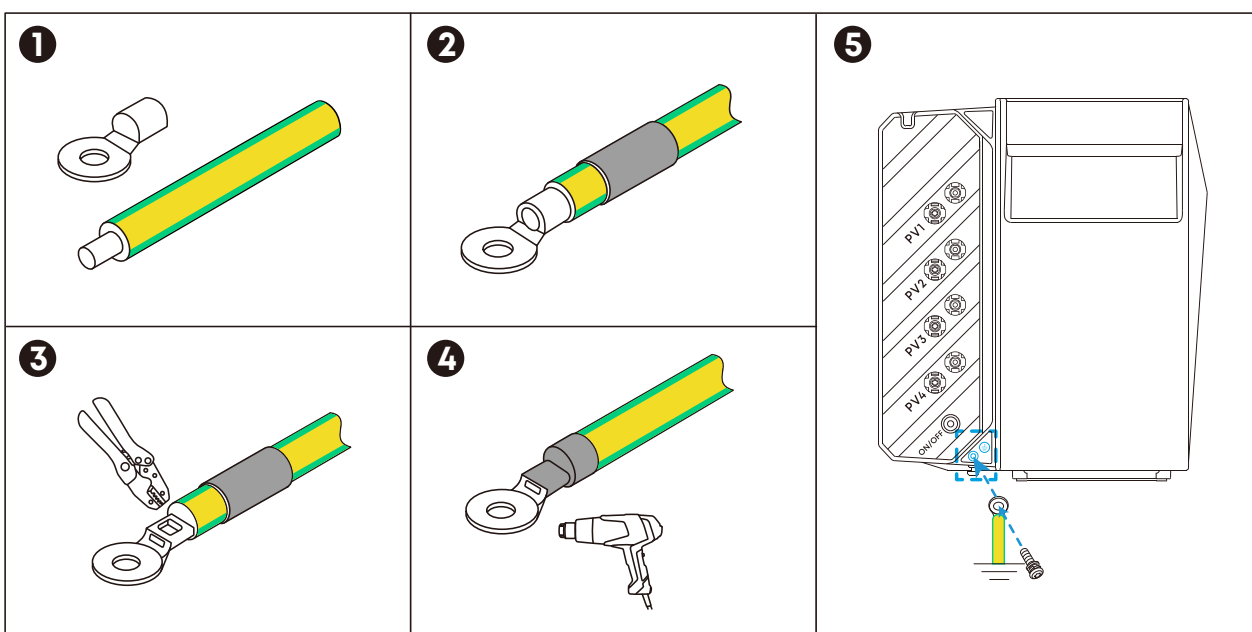

Connect to PV Modules

- Ensure that unused PV ports on Solarbank are sealed with waterproof caps.
- When connecting PV modules in parallel, please check the specifications of the PV modules and ensure that the total short-circuit current does not exceed 40A.
- It is recommended to use PV cables shorter than 3 m. Longer cables may cause interference to certain electronic devices.
- Never connect two or more PV modules in series because this causes the input voltage to exceed 60V and will damage the equipment.

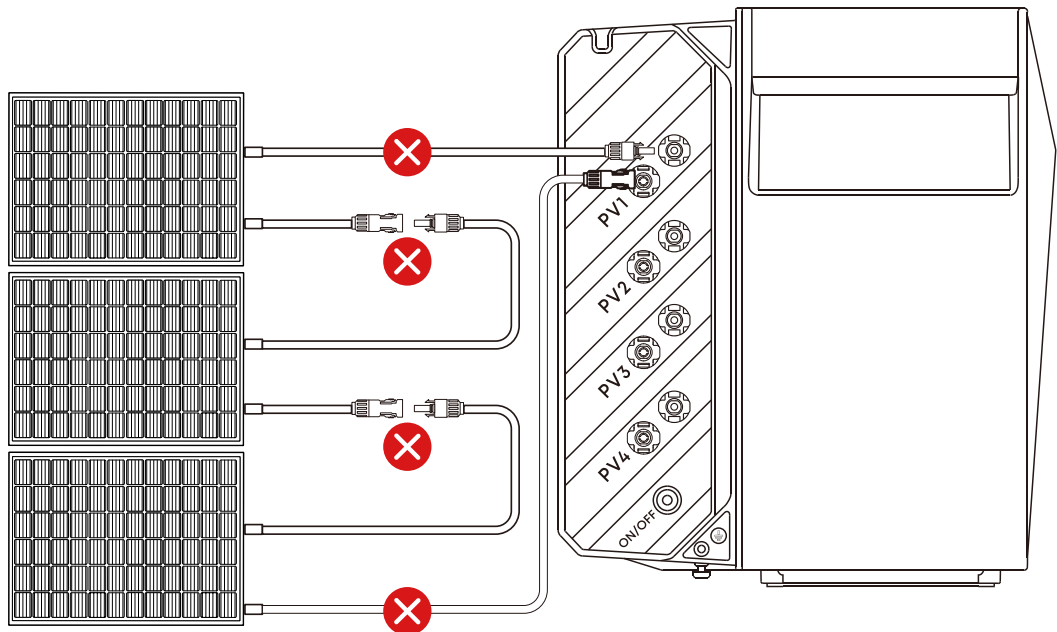

Never connect the same set of PV connectors to different sets of PV input ports. For instance, connecting the positive connector of PV Module 1 to the negative PV2 input port of Solarbank is prohibited.

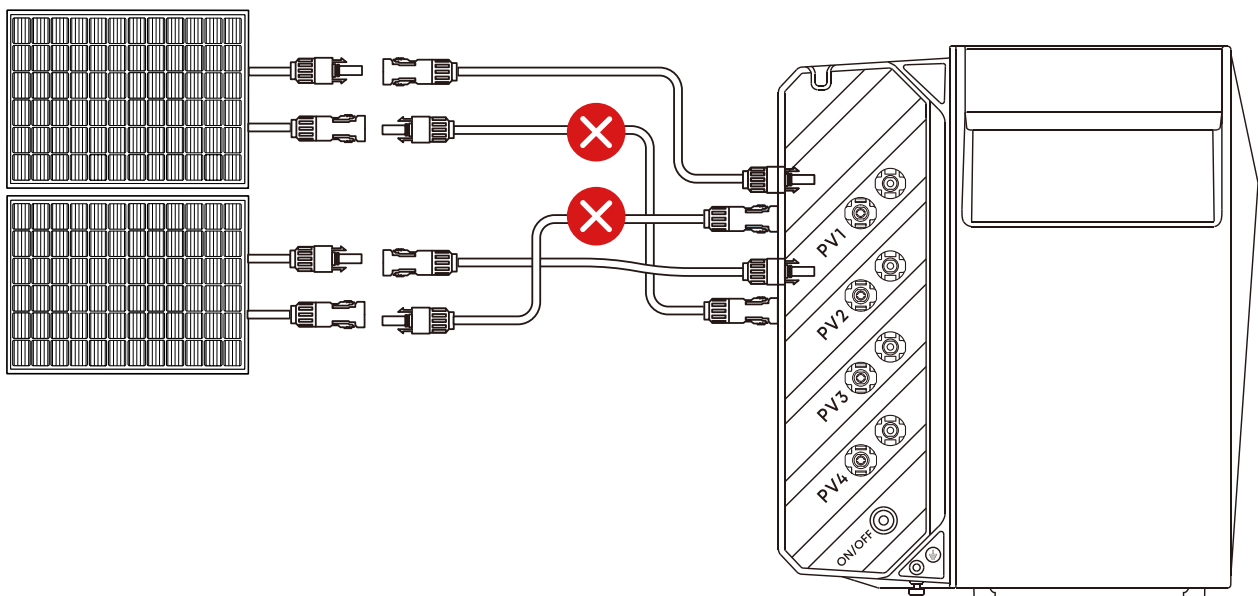

Direct Connection (Up to 4 PV Modules)

Connect each PV module directly to the same set of PV input ports.

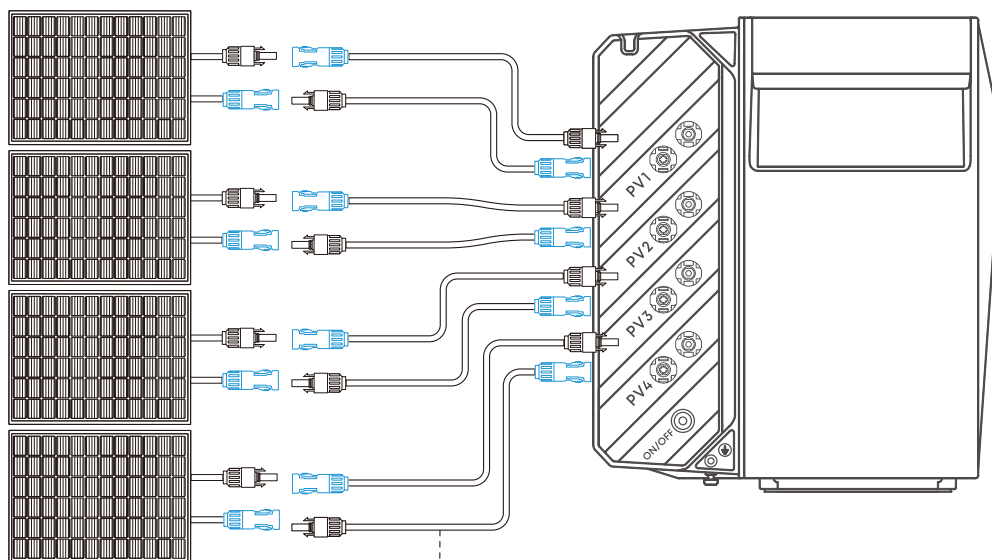

Anker SOLIX Solar Panel
Extension Cable (sold separately)

Parallel Connection (Up to 8 PV Modules)

Connect every two PV modules to the same set of PV input ports.

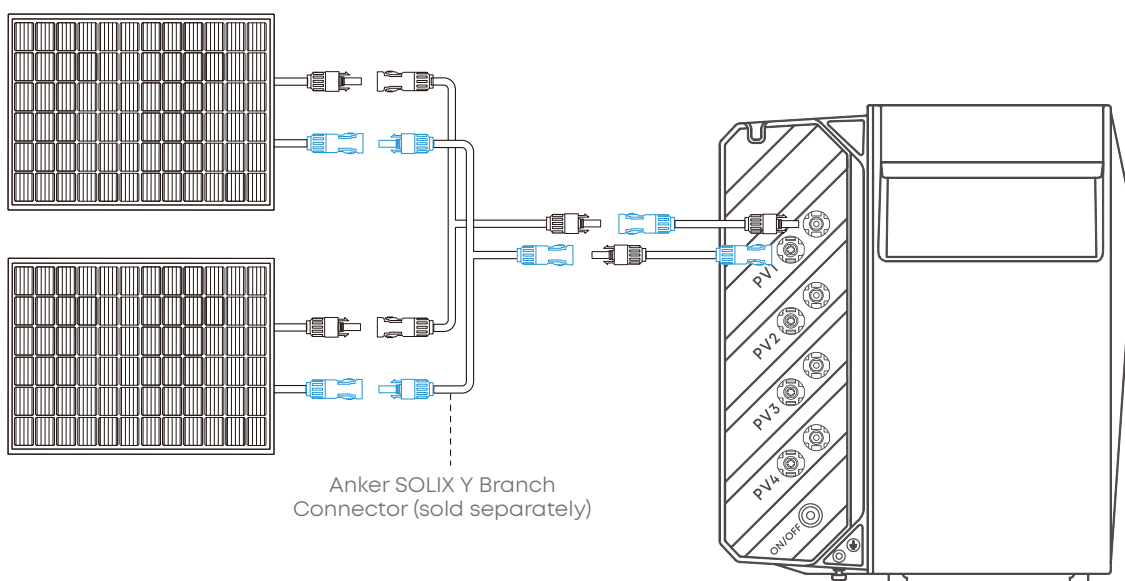

Anker SOLIX Y Branch
Connector (sold separately)

Parallel Connection (Up to 12 PV Modules)

Connect every three PV modules to the same set of PV input ports.

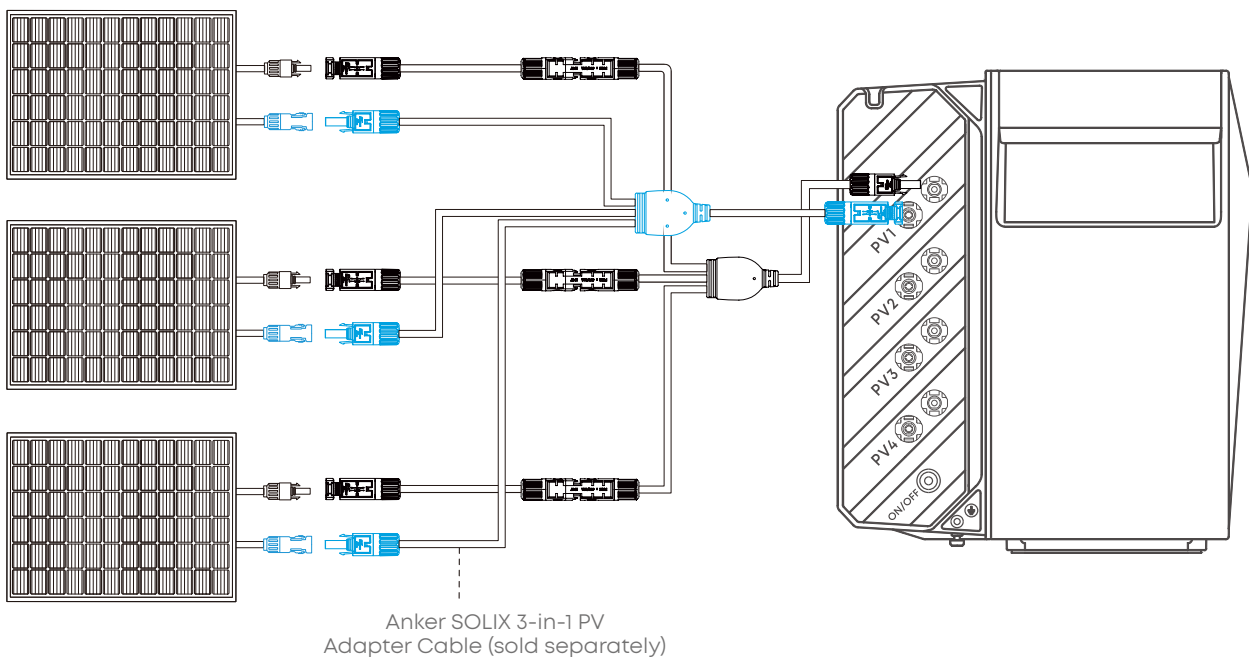

Third-Party Solar Cable Requirements

When using third-party solar cables with your Solarbank, ensure that each cable meets the following specifications.

Current	Conductor Cross-Sectional Area
≤ 25A	4 mm ²
25A to 35A	6 mm ²

Example: The figure below shows solar cable specifications for a PV module with 16A DC output per port.

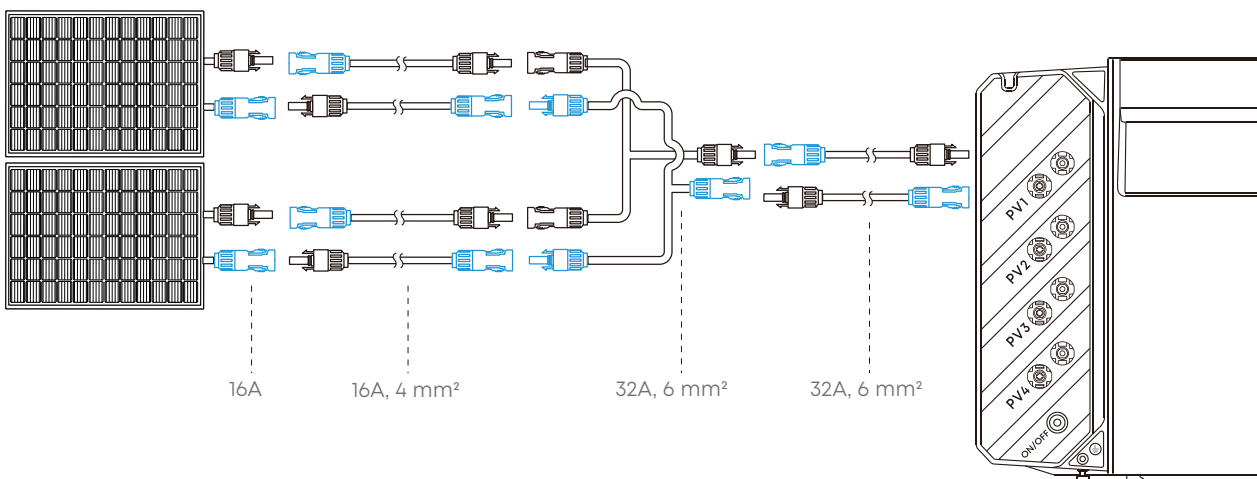



To disconnect the PV connectors, use the included wrench.

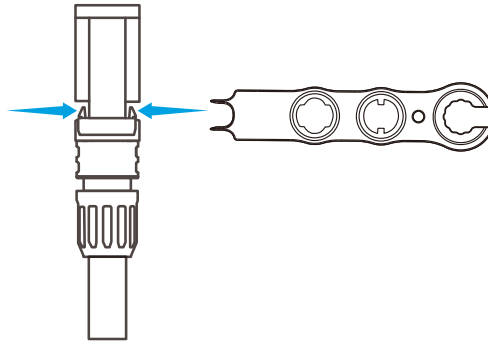

Connect to the Grid

Option 1: Via Socket



Ensure the AC cable is fully inserted into the on-grid terminal until you hear a click.

1. Remove the plug.
2. Connect Solarbank to a home outlet with included AC cable.

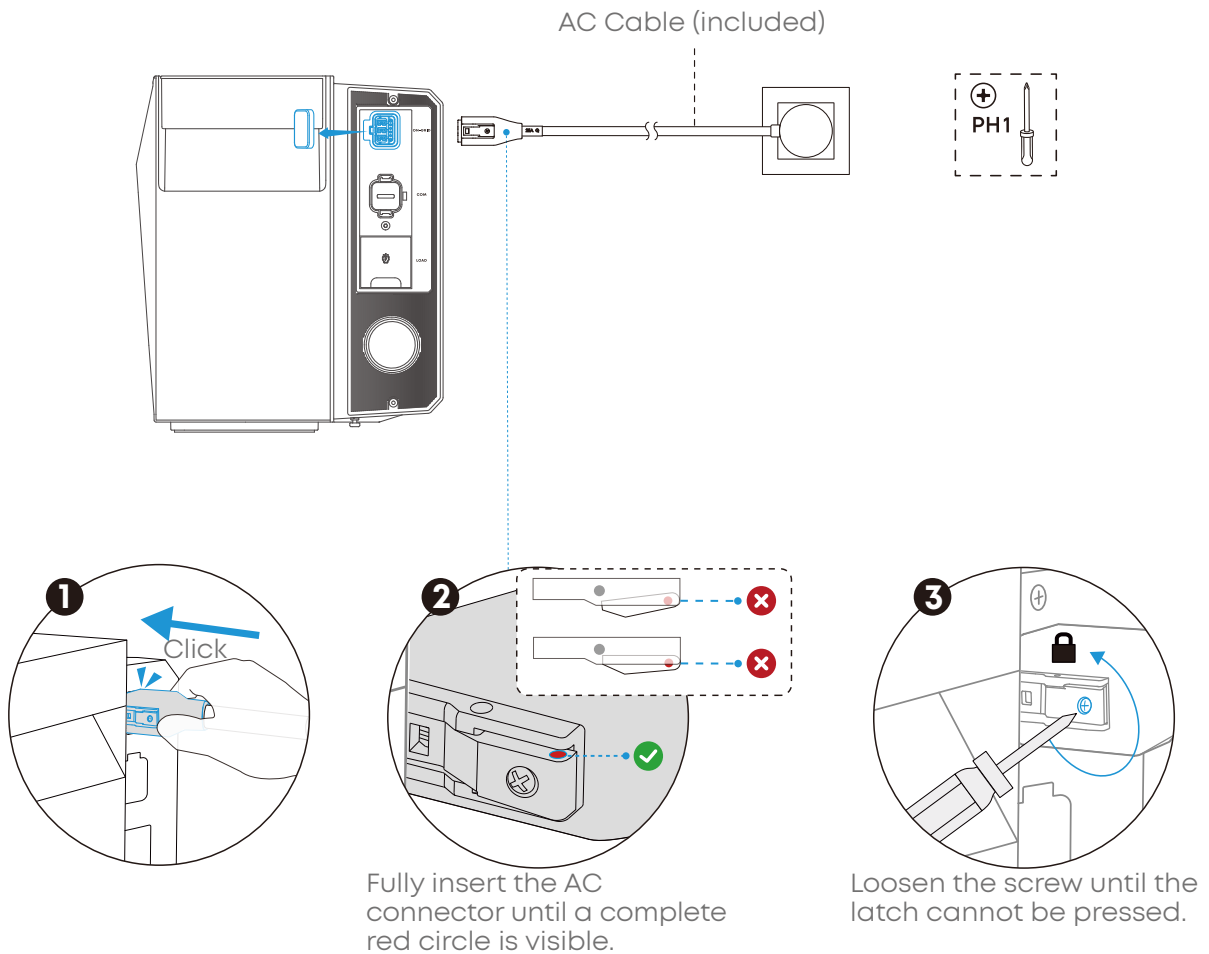

Option 2: Via Wieland Socket



Ensure the AC cable is fully inserted into the on-grid terminal until you hear a click.

CAUTION

- All applicable local electrical codes, safety standards, and regulations must be followed.
- All installation work must be performed by a licensed electrician. Failure to do so may result in electric shock, fire, or property damage.
- For energy storage systems under 2500 W, registration with a qualified electrician is a mandatory legal requirement. Anker SOLIX is not liable for any issues arising from failure to register.

Prepare a Dedicated Circuit

Use one of the following methods to locate or add a dedicated circuit. It is recommended to consult a qualified electrician to verify the dedicated circuit and assess the circuit condition to ensure compliance with applicable requirements.

Method 1: Check the Wiring Diagram

Refer to your home wiring diagram to locate a socket on a dedicated circuit.

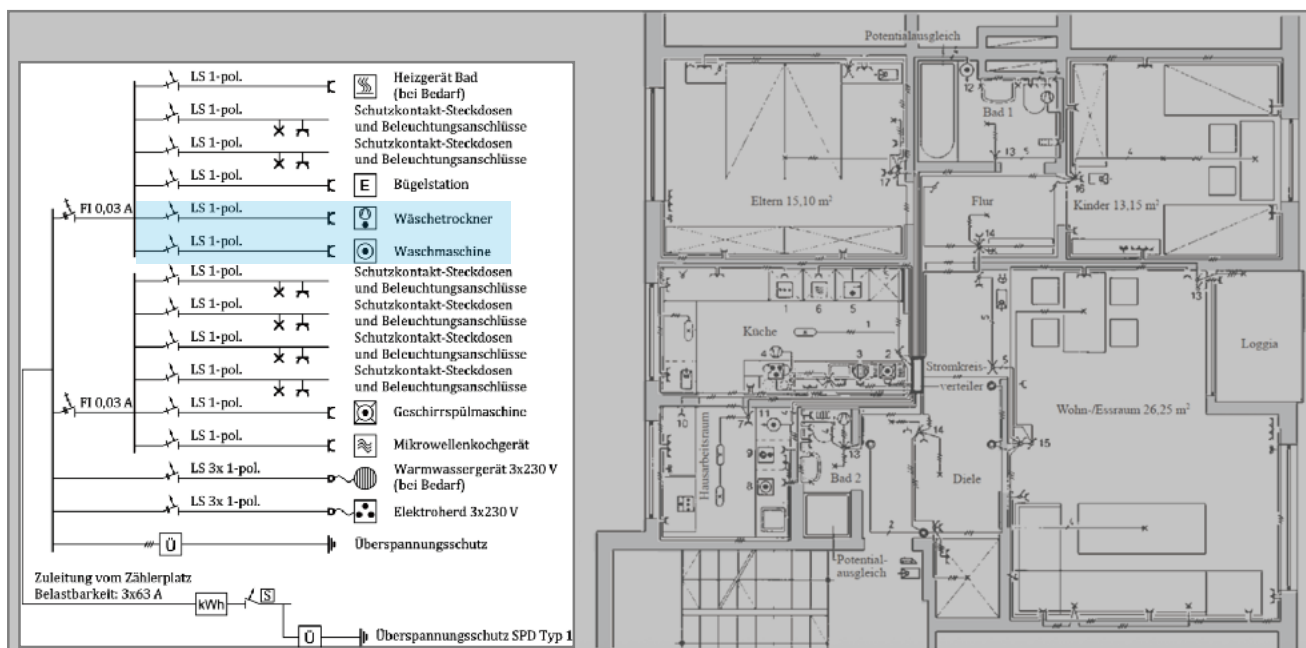

Method 2: Check the Circuit Label

Open the electrical panel and find a breaker or RCBO label assigned to only one appliance.

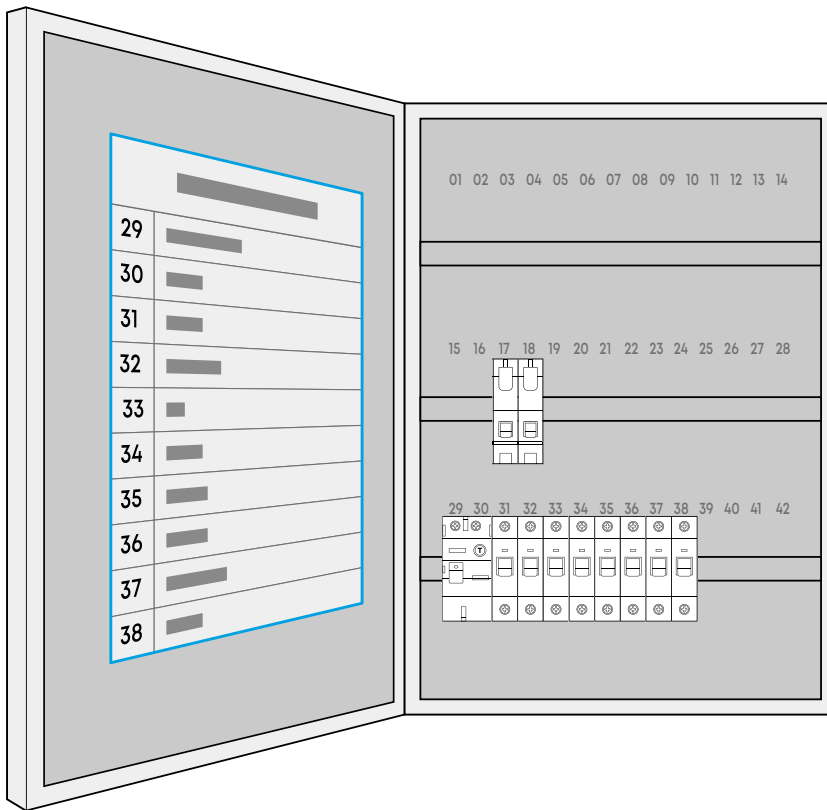

Method 3: Check the Breaker Mark

Locate the breaker typically marked as 16A, B16, or C16.

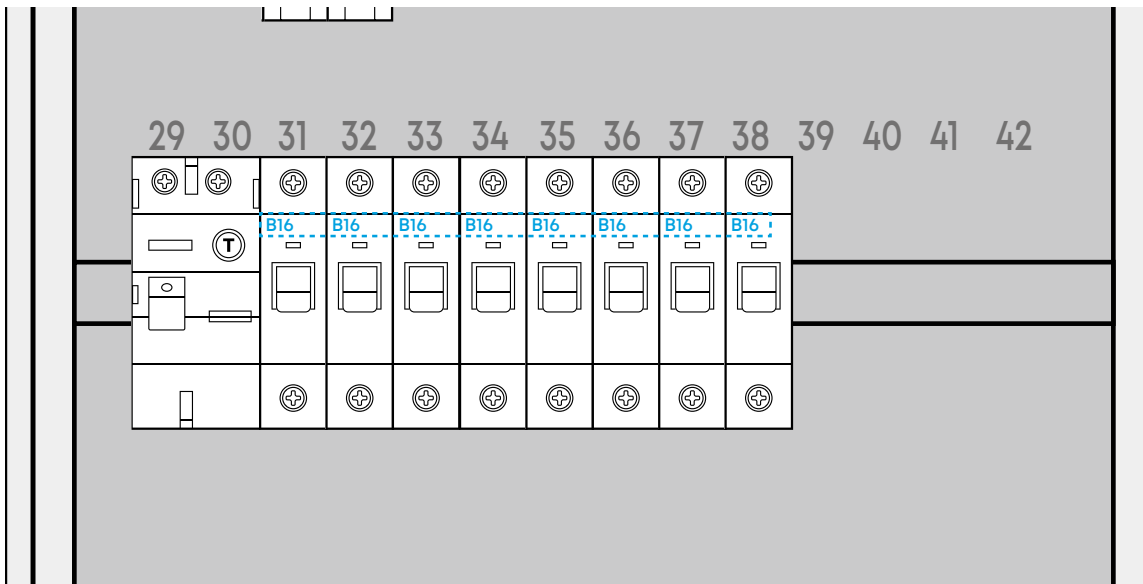

Method 4: Add a Dedicated Circuit

If no dedicated circuit is available, contact a licensed electrician to install one.

Select a Suitable Socket

If Solarbank is connected through a wall socket or a Wieland socket, select a suitable socket on the dedicated circuit. If Solarbank is connected directly to the main panel, skip this section.

1. Confirm the Installation Location

Identify the appliance or socket served by that circuit, and check whether there is a suitable location nearby for Solarbank.

- Ideal spots: laundry rooms, attics, garden sheds, garages, and storage rooms.
- Avoid: kitchens, bathrooms, or areas with flammable or explosive materials.

2. Check Socket Condition and Rating

Make sure the socket is in good condition, with no damage or signs of aging, and supports the required current (16A for EU).

If the socket does not meet these requirements, switch off the breaker for that socket and replace the socket.



*The socket appearance is for reference only and varies by region.

3. Turn Off the Target Circuit

Switch off the breaker or RCBO for the target circuit.

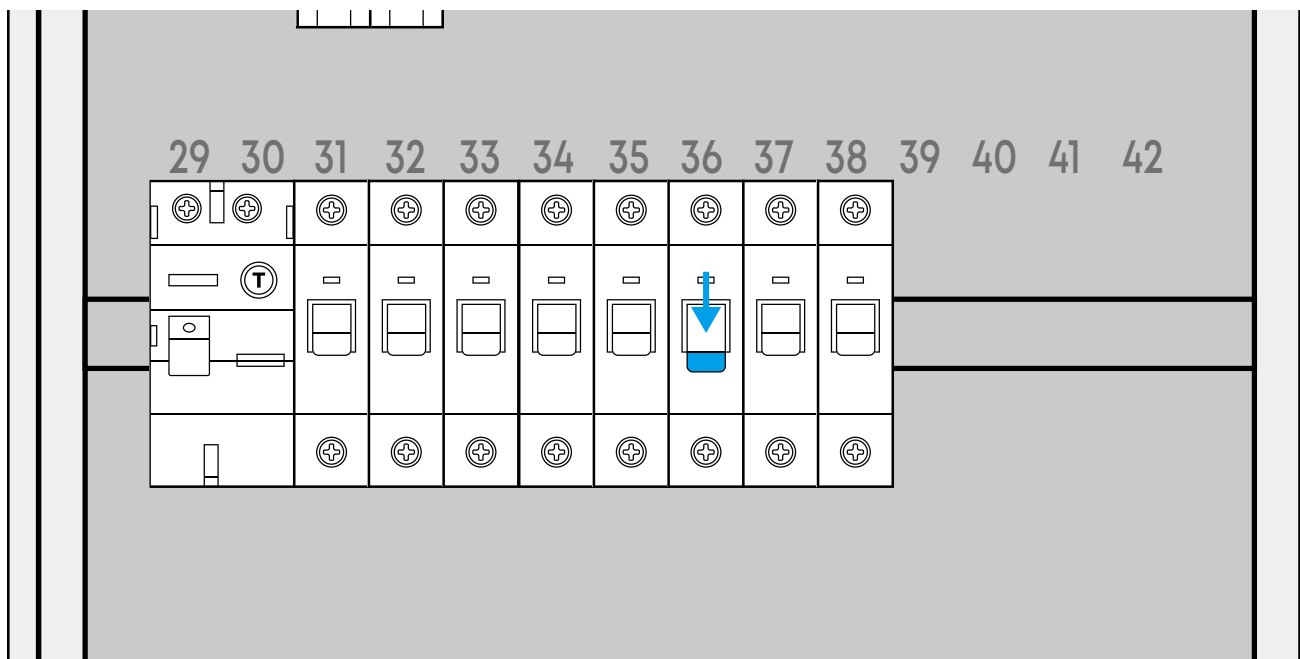

4. Test the Target Socket

Test the target socket with a voltage tester or a lamp. With the breaker switched off, the tester should not light up, or the lamp should remain off.

5. Confirm That the Circuit Is Dedicated

Test other sockets in your home with the same tool. If they remain powered, the target socket is on a dedicated circuit.

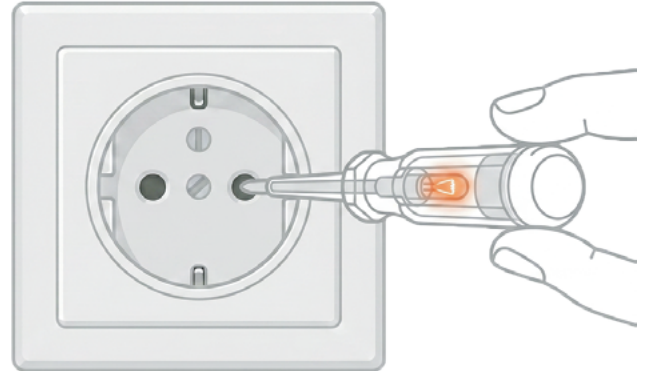
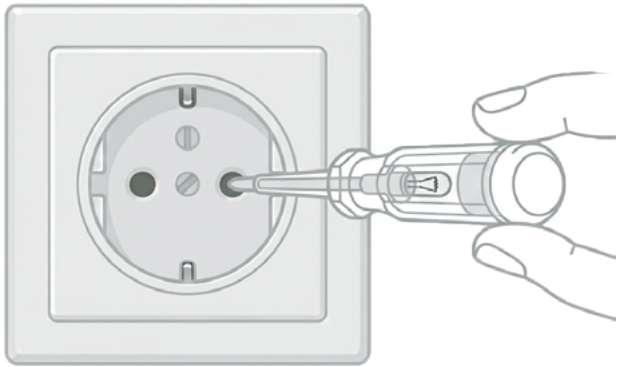

Install the Wieland Socket

1. Assemble the socket panel.

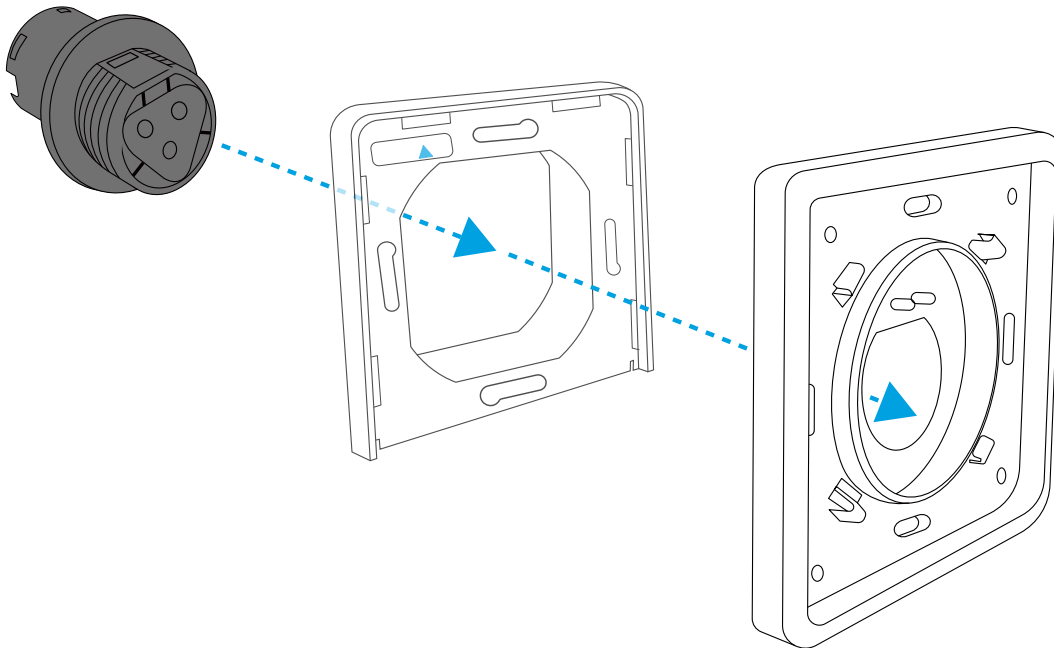

2. Install the manual release ring.

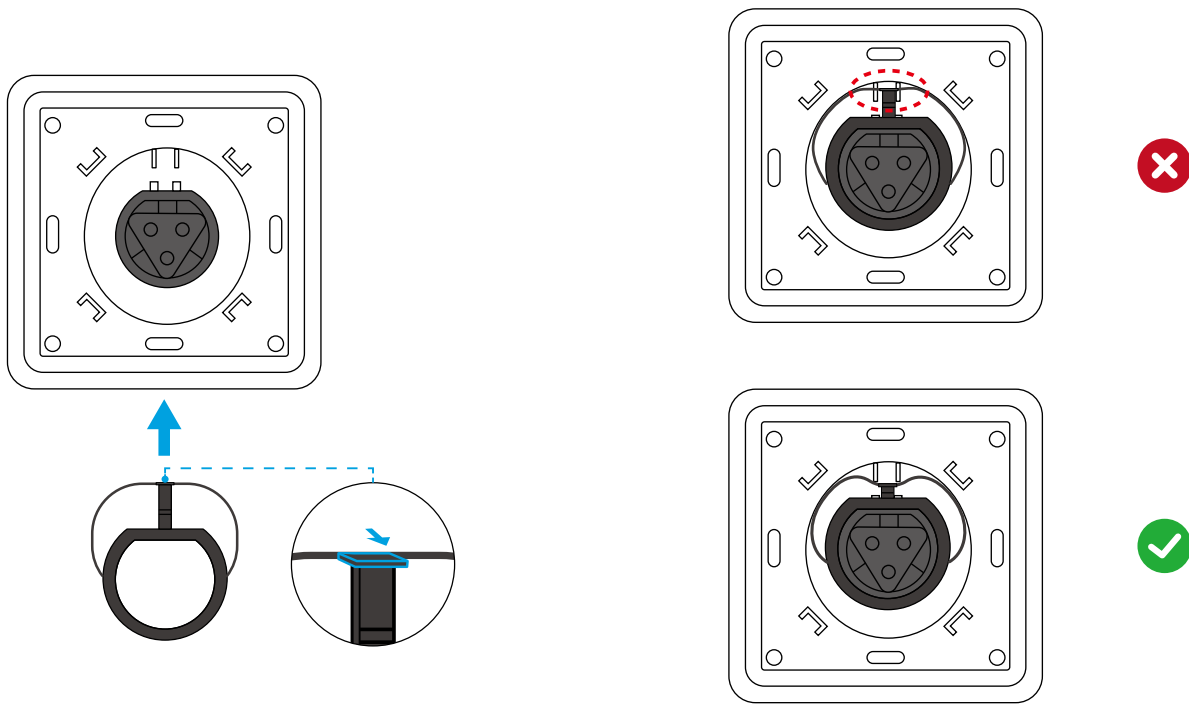

3. Tighten the lock nut.

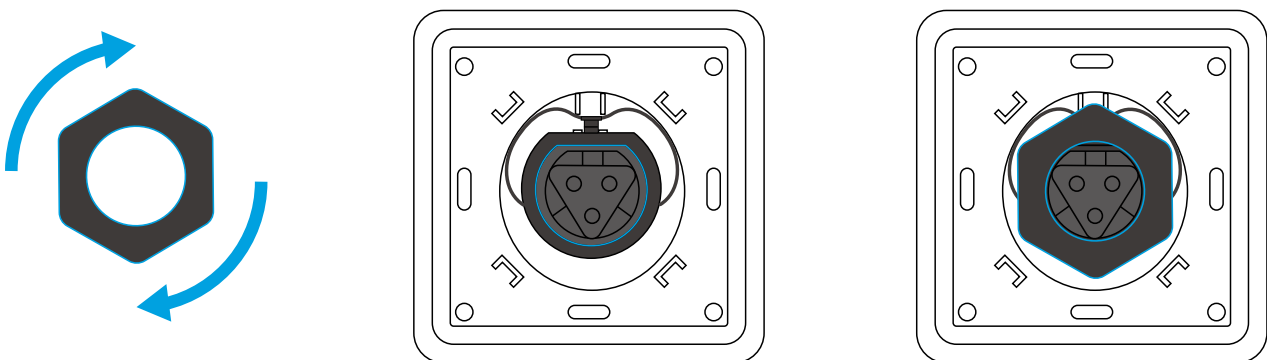

4. Prepare the cable.

Solid Cable

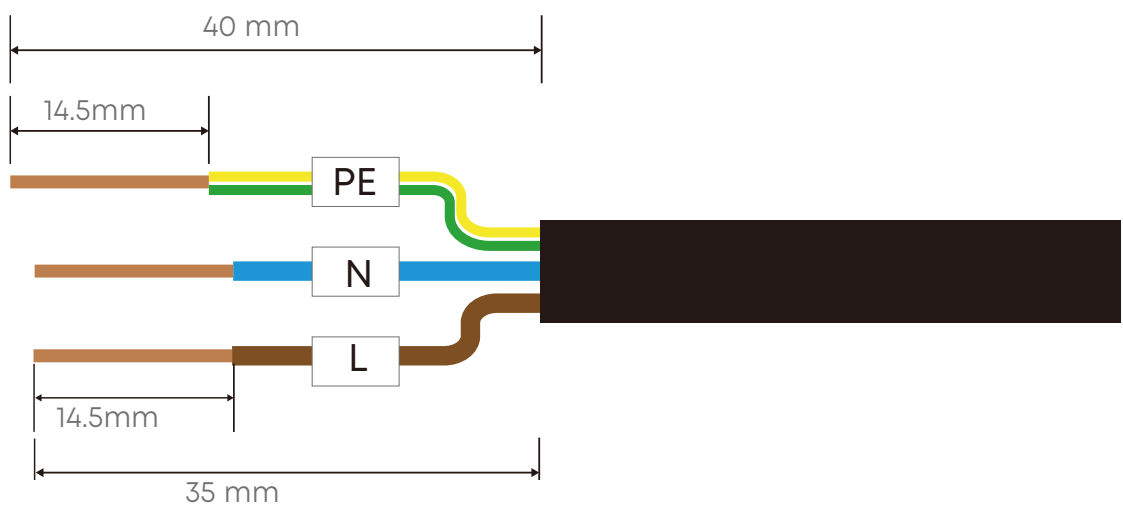

Stranded Cable

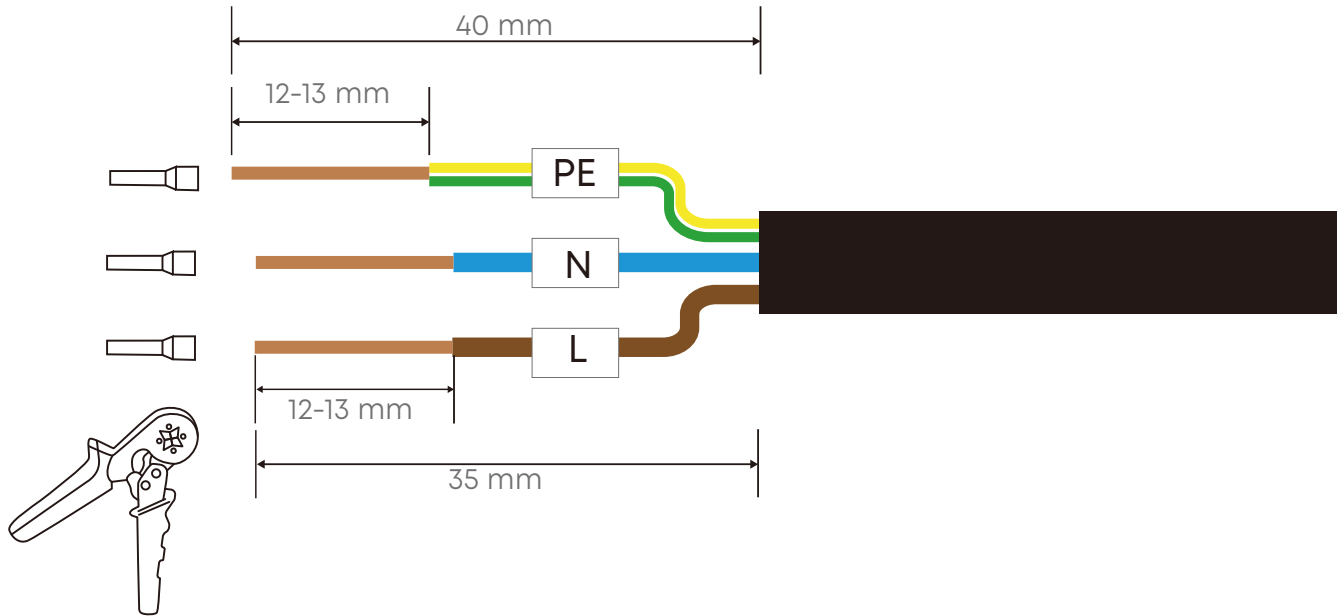

5. Connect cables to the connector.

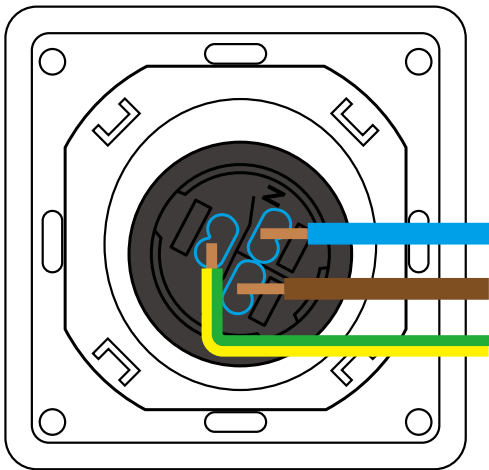

6. Secure the panel to the wall.

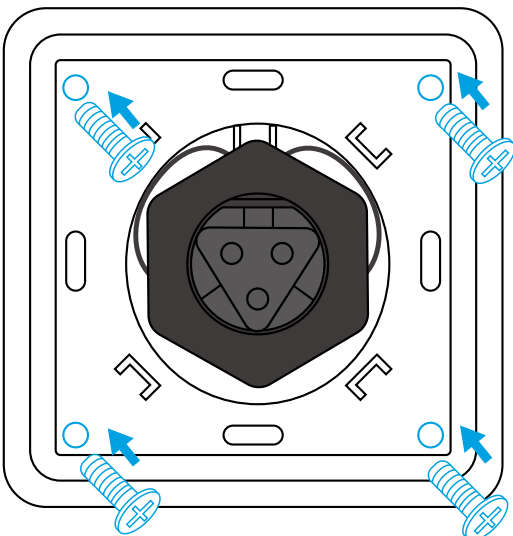

7. Snap the front cover onto the assembled panel.

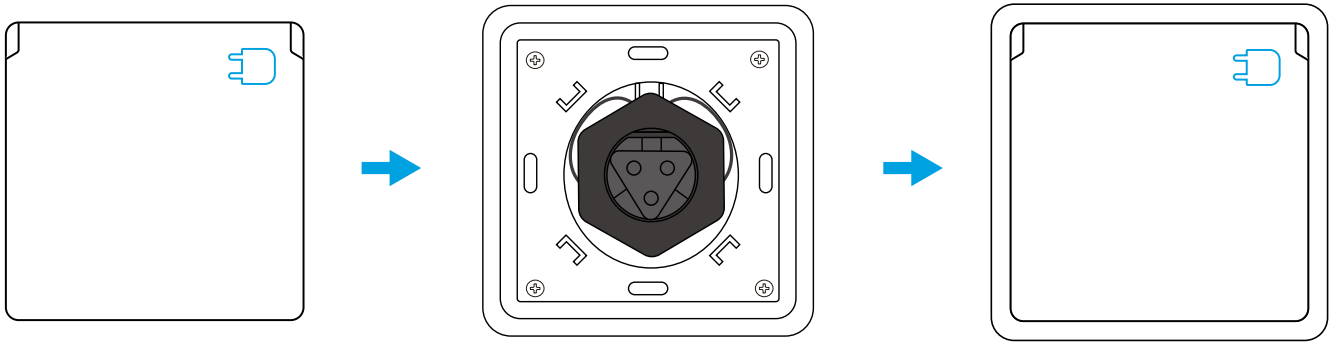

8. Insert the AC connector into the Solarbank.

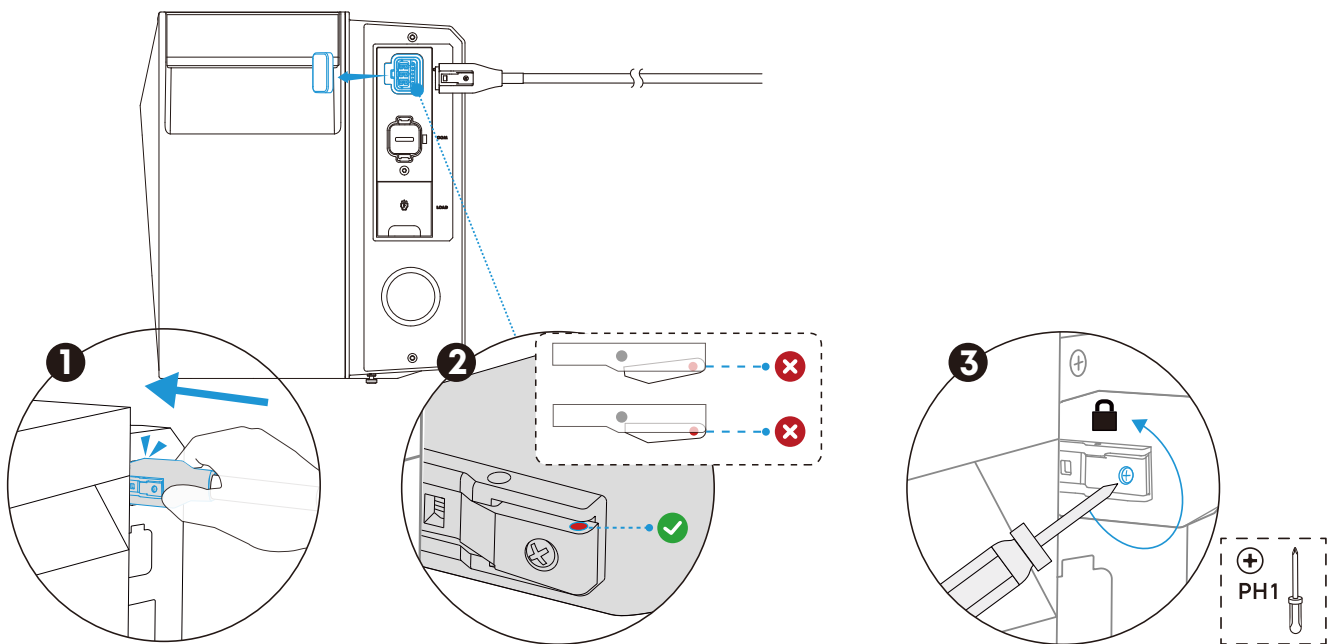

Fully insert the AC connector until a complete red circle is visible.

Loosen the screw until the latch cannot be pressed.

9. Connect the Wieland Plug into the dedicated circuit socket.

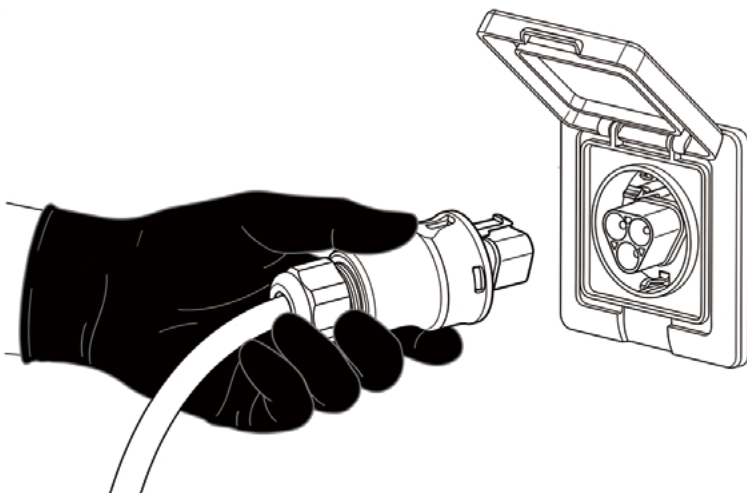

Option 3: Via Main Panel



The AC Connection Terminal is sold separately.

CAUTION



- All applicable local electrical codes, safety standards, and regulations must be followed.
- All installation work must be performed by a licensed electrician. Failure to do so may result in electric shock, fire, or property damage.

1. Strip insulation layers.

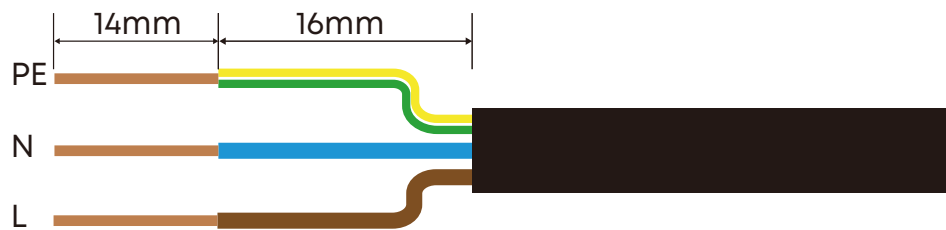

2. Disassemble the AC connector.

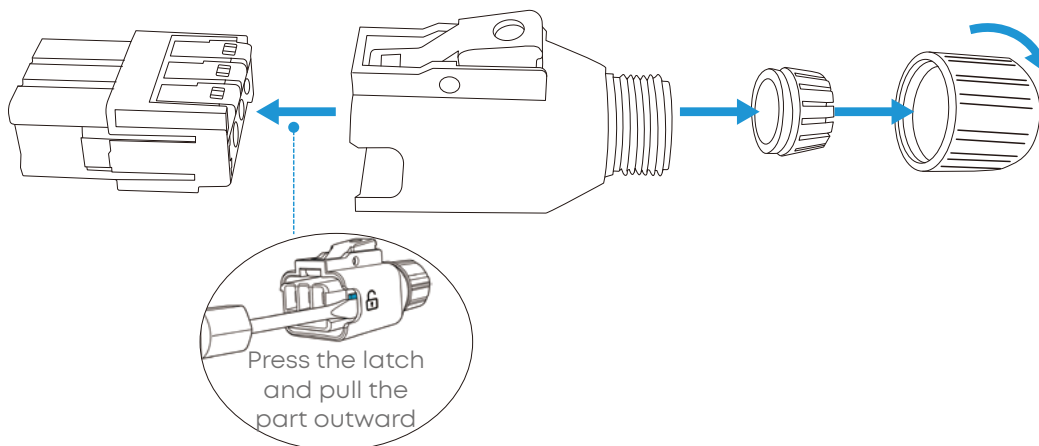

3. Connect cables to terminals.



If using stranded wire:

1. Twist all strands into a tight bundle and insert fully into the terminal opening before pressing the lever closed.
2. Gently pull the wire to confirm a secure connection after pressing the lever down.

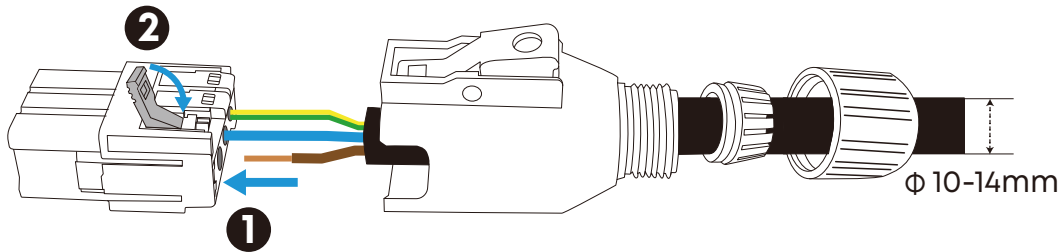

4. Assemble the AC connector



Ensure the nut is securely tightened to maintain the waterproof seal.

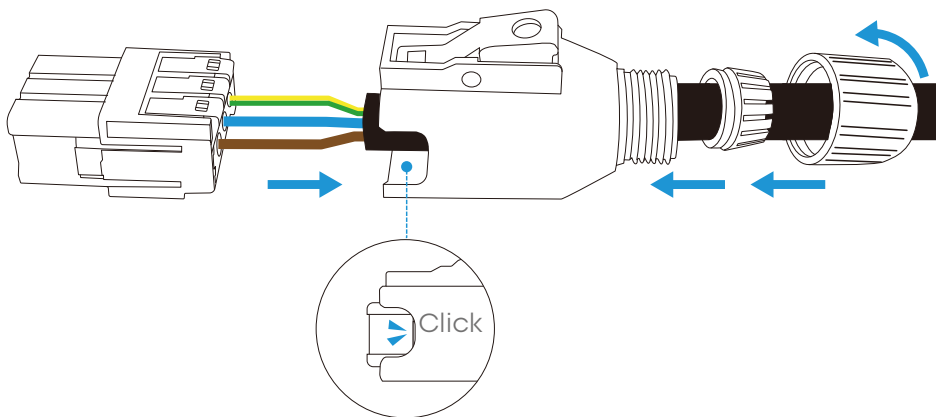

5. Insert the AC connector into the Solarbank.

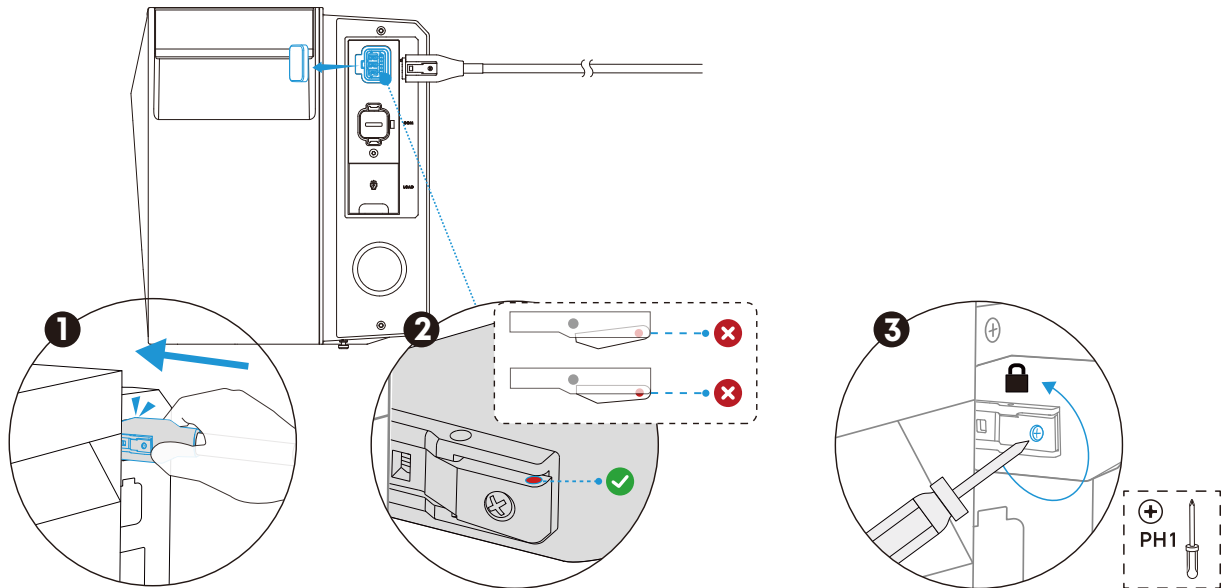

Fully insert the AC connector until a complete red circle is visible.

Loosen the screw until the latch cannot be pressed.

6. Connect the other ends of the power cables to the main panel.

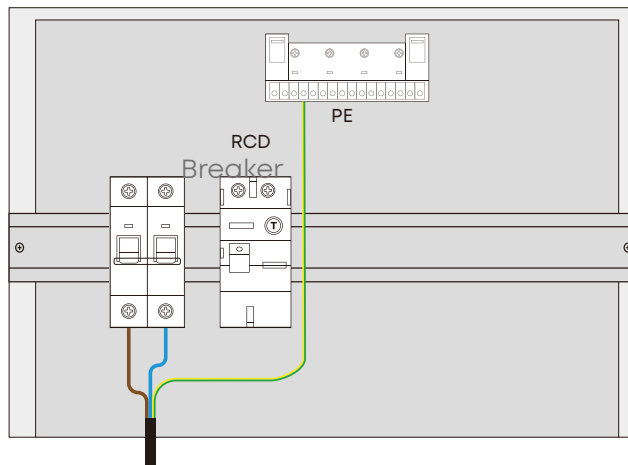

Connect to Your Device

Power your device directly using the backup terminal if needed.

Insert the plug fully into the terminal.

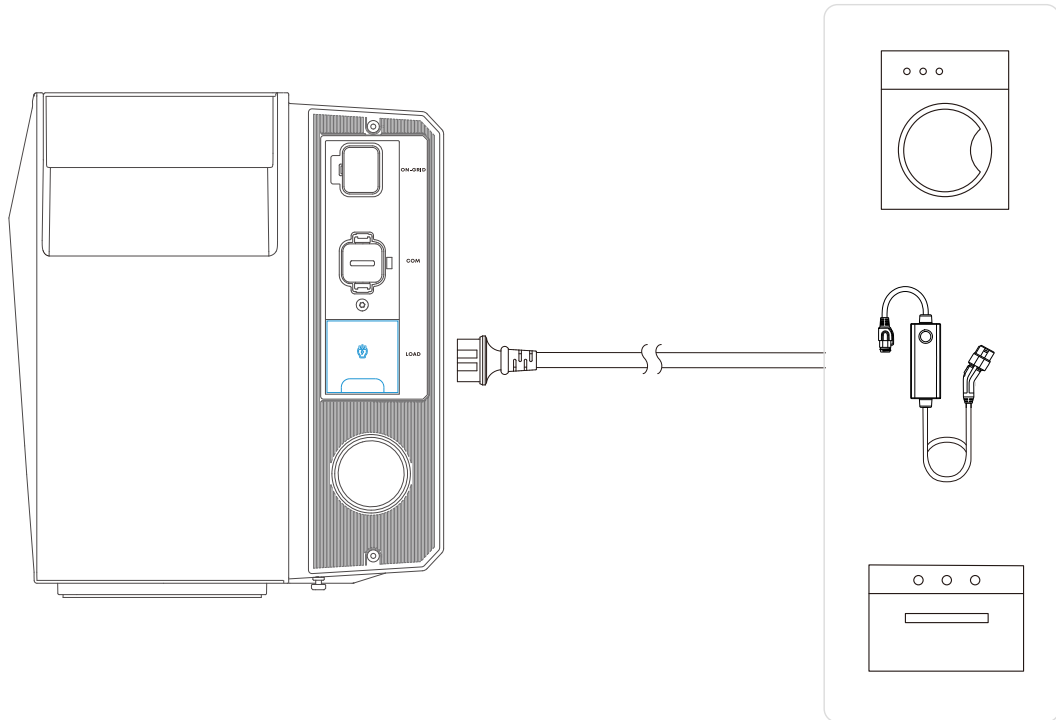

(Optional) Install the Smart Meter

Solarbank can be used with Anker SOLIX Smart Meter and Anker SOLIX Smart Meter Gen2. For installation instructions, please refer to:

[Anker SOLIX Smart Meter User Guide \(A17X7\)](#)

[Anker SOLIX Smart Meter Gen 2 User Guide \(AE1X0\)](#)

(Optional) Install the Smart Plug

Solarbank can be used with Anker SOLIX Smart Plug and Anker SOLIX Smart Plug Gen2. For installation instructions, please refer to:

[Anker SOLIX Smart Plug User Guide \(A17X8\)](#)

[Anker SOLIX Smart Plug Gen 2 User Guide \(A17X8312\)](#)

(Optional) Connect the Communication Cables

Port Definitions

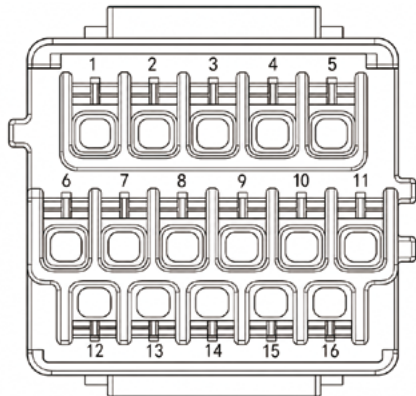

Pin	Signal	Function
1	HP DRV1+	Used to connect Heat Pump 1
2	HP DRV1-	
3	/	Reserved
4	HP DRV2+	Used to connect Heat Pump 2
5	HP DRV2-	
6	RS485+ Meter	Used to connect the meter
7	RS485- Meter	
8	RS485+ Others	Used to connect other equipment over RS485
9	RS485- Others	
10	CAN3 H	Used to connect the combiner box
11	CAN3 L	
12	DRM8 ARM+	Rapid Shutdown
13	DC ISO GND1	
14	DC ISO GND1	DI-
15	DC ISO GND1	DI-
16	DRMO ARM+	DI+

Connect the Communication Cable



The method to connect different communication cables is the same. This section takes connecting the RS485 cable as an example.

1. Use a flathead screwdriver to pry the top and bottom tabs of the cover to release it. Then pinch the tabs and pull the cover out of the COM port.

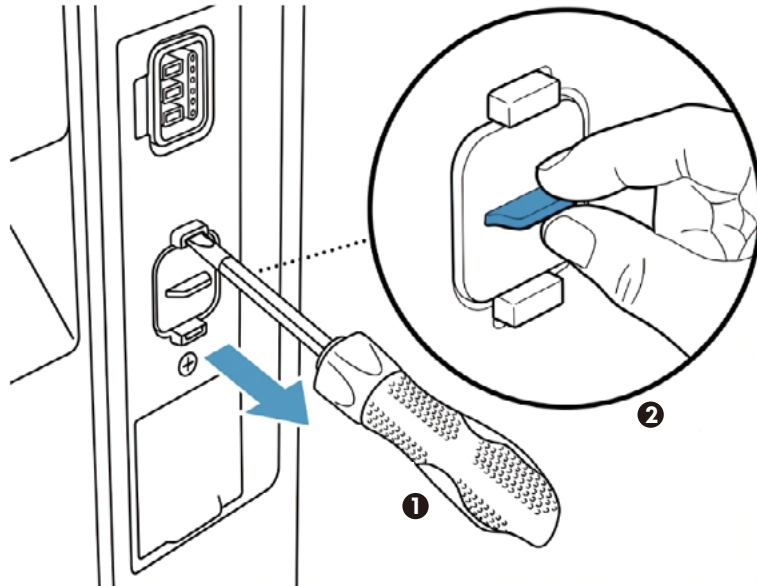

2. Disassemble the COM connector and take out a waterproof plug.

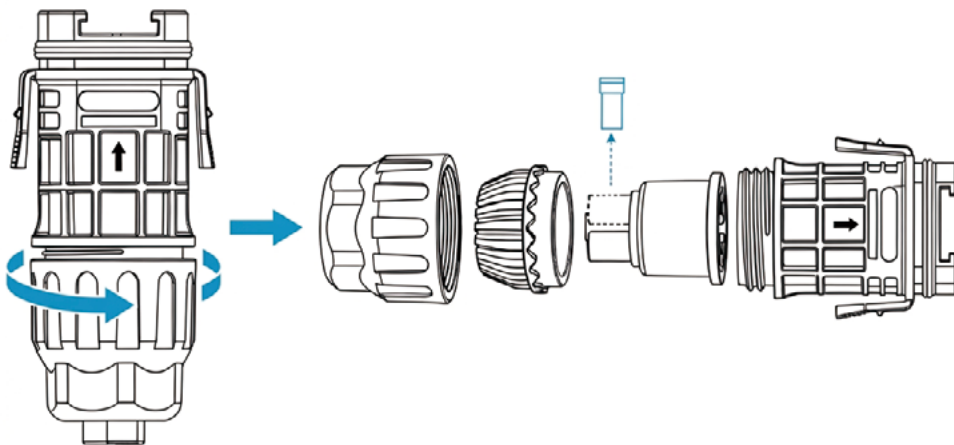

3. Crimp the RS485 Cable.

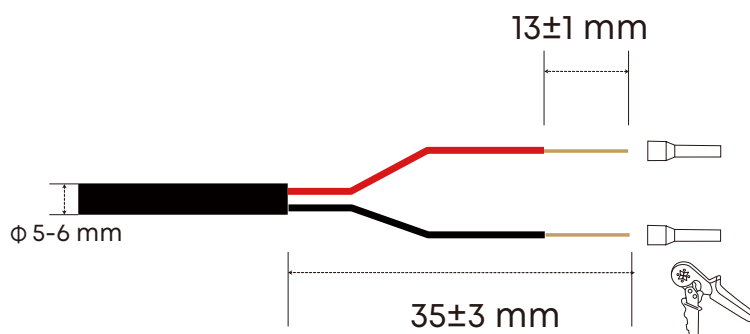

4. Route the RS485 cable through the connector and insert the tube terminals into the 16-pin terminal block connector.

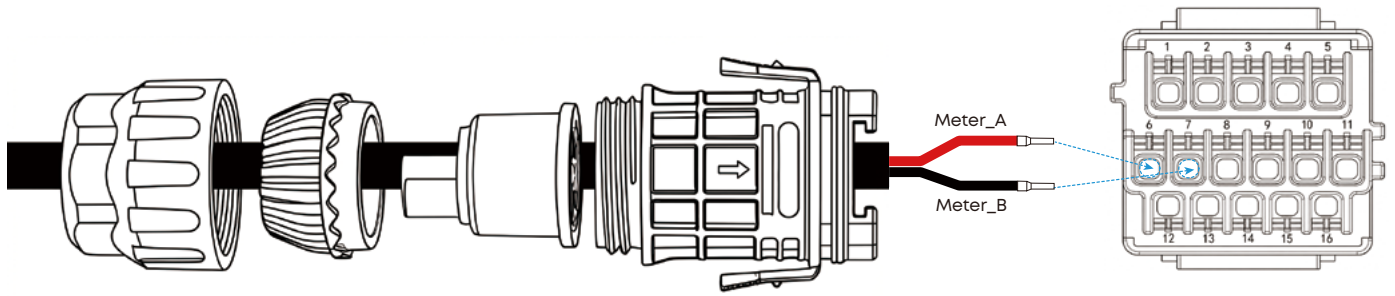

5. Assemble the COM connector.

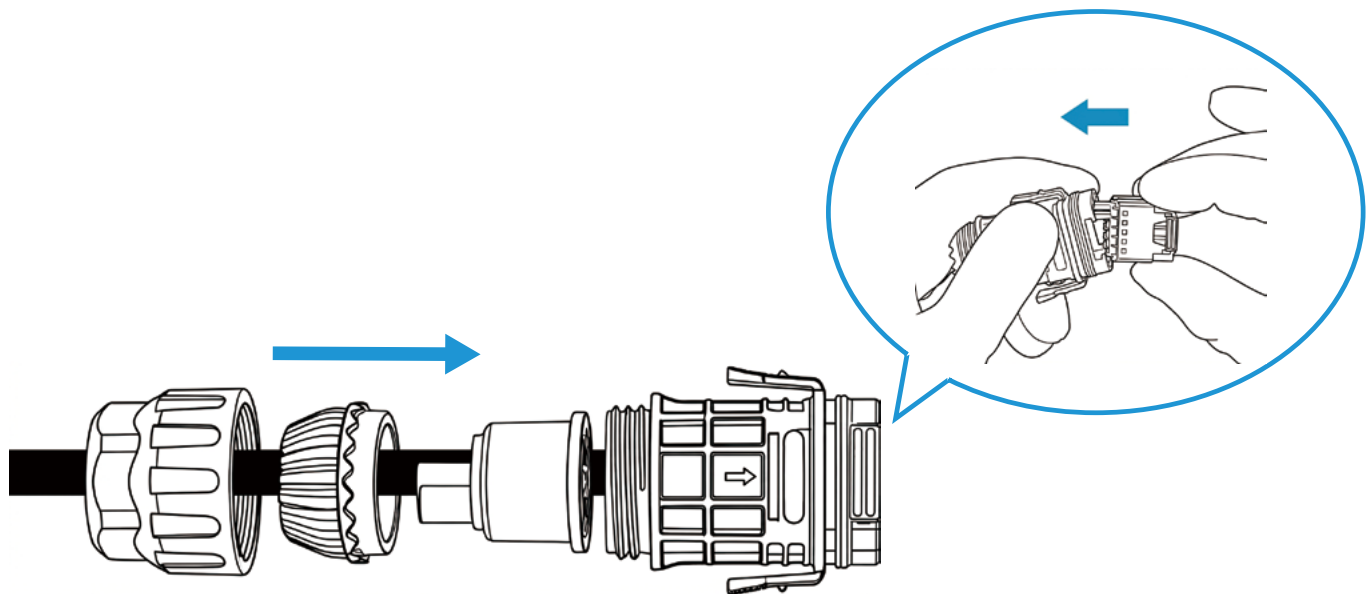

6. Fully insert the COM connector into the solarbank.

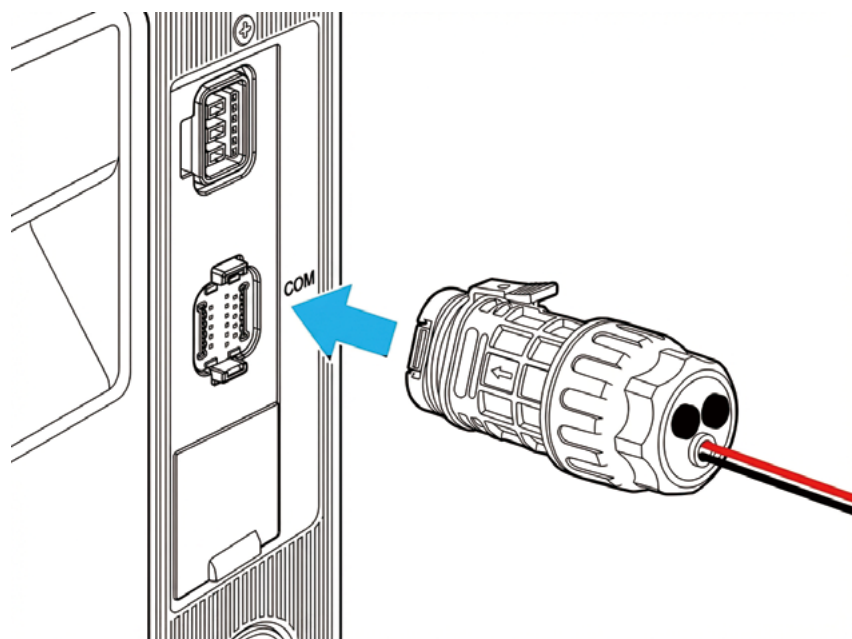

Device Setup

Power On / Off

The first use requires the connection to a PV module and a home outlet.

- **With solar or AC input:** Solarbank turns on automatically. To turn it off, disconnect it from both the PV modules and the home outlet, and then press the power button for 2 seconds.
- **Without solar and AC input:** Press the power button for 2 seconds to turn Solarbank on or off.

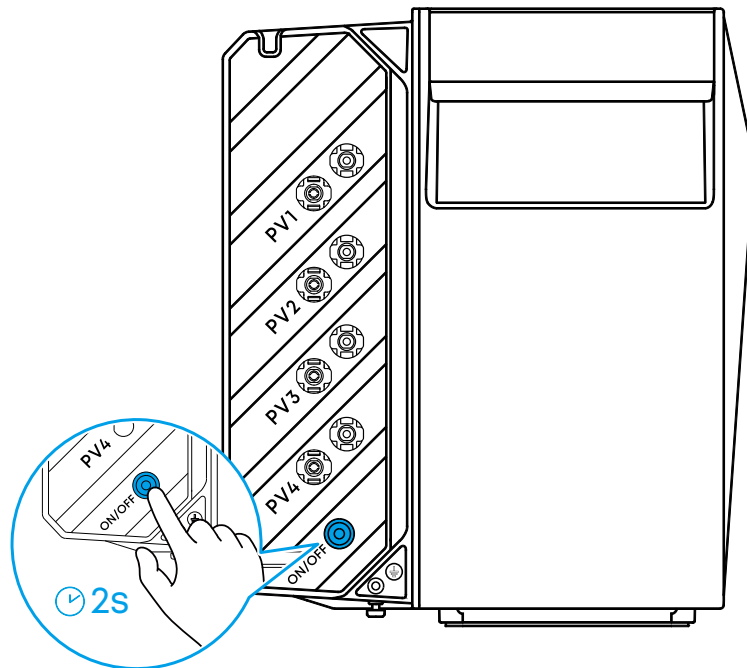

Confirm Networking Status

Solarbank enters networking mode automatically when powered on. Ensure the IoT button is flashing blue.



Connect to the network using the Anker app within 30 minutes or Solarbank will turn off.

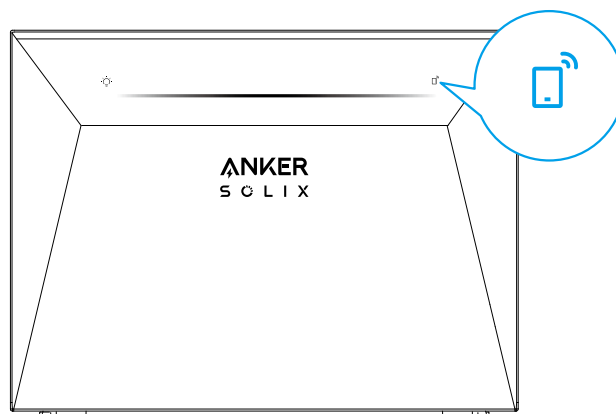

Use the Anker App

The Anker App allows you to monitor and manage your Solarbank system easily. Please note that the user interface images displayed are for illustration purposes and may differ from your actual view based on the software version.

Download the Anker App

Download the Anker app from the App Store (iOS devices) or Google Play (Android devices), or by scanning the QR code.

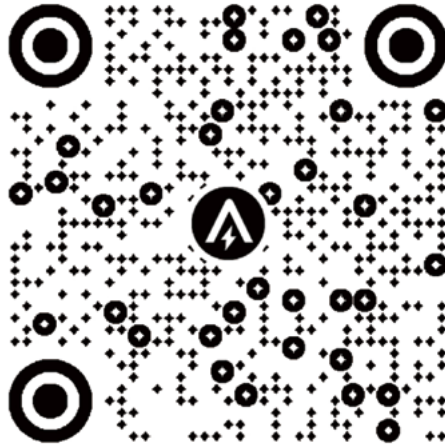

Sign Up / Sign In

Sign in or create an account. Please be reminded that the country or region MUST match where you live. An incorrect country or region may cause the device connection to fail.

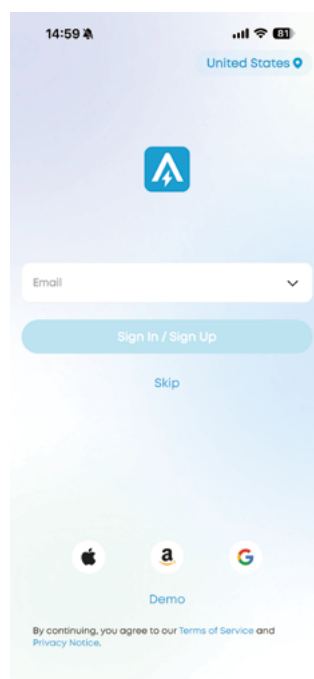

Add Device

- ① On the Devices screen, tap Add Devices or the plus icon on the top right.
- ② Select your Solarbank.
- ③ Press the IoT button to complete the connection.

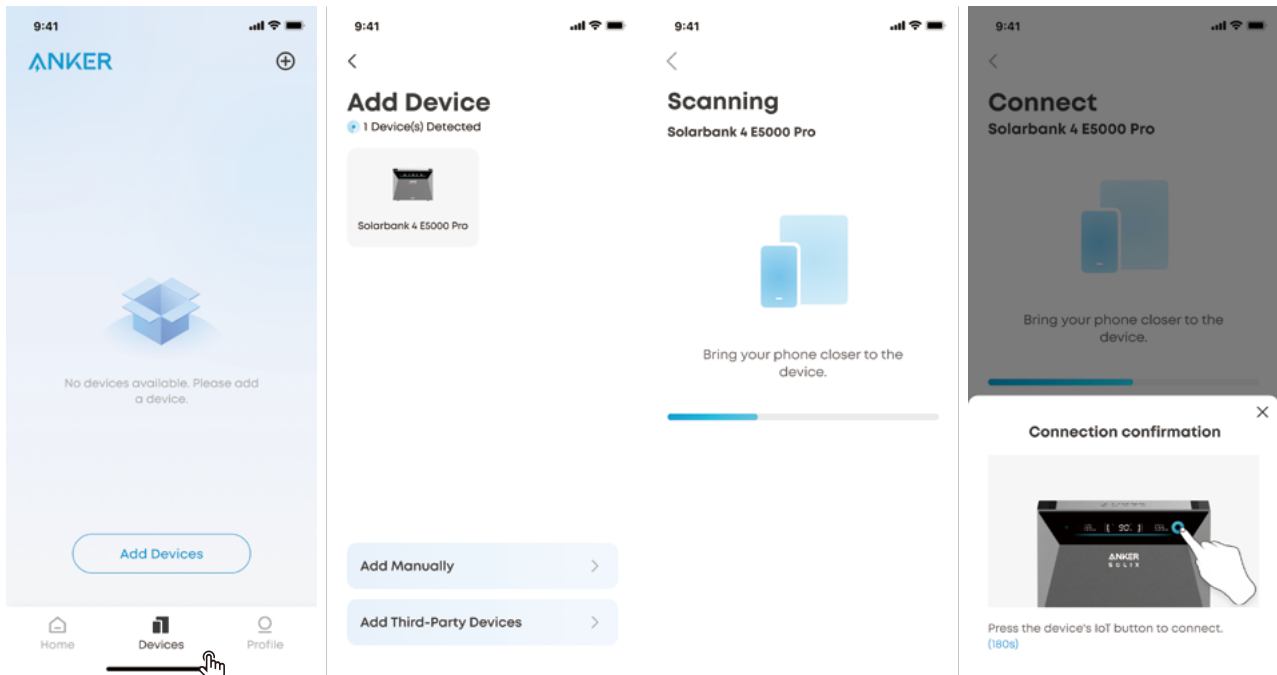

Select Scene

Select from Build a Power System and Power Independently based on your installation scenarios.

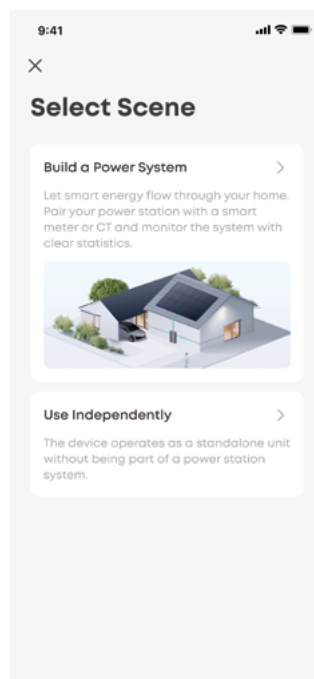

Initialization Settings

The initialization steps may vary depending on your selected installation scenario. Follow the in-app instructions to complete the setup.

Connect to a Network

Set up the network connection with a 2.4 GHz WiFi network.

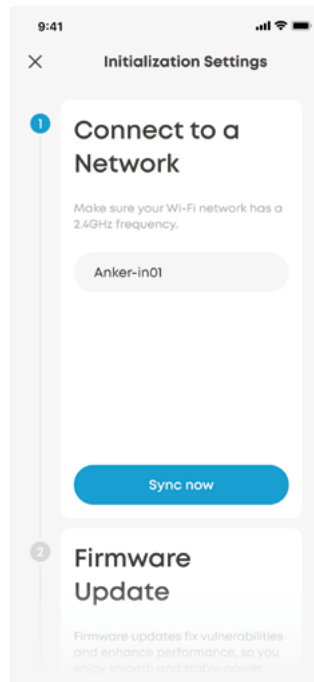

Add Another Device

- ① Tap Go to add to add more devices to your system.
- ② Tap Add to select the types of devices to be added.
- ③ Connect Bluetooth and Wi-Fi
- ④ Tap to select devices to be added. Then tap Select to proceed.
- ⑤ Once all devices have been added, tap Done to proceed.

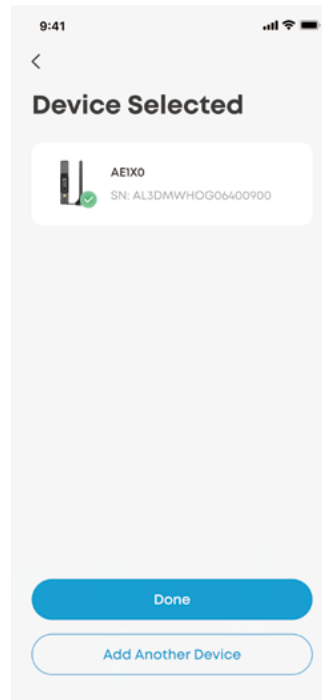
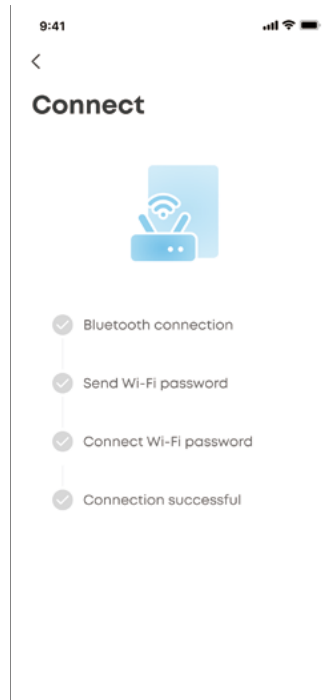
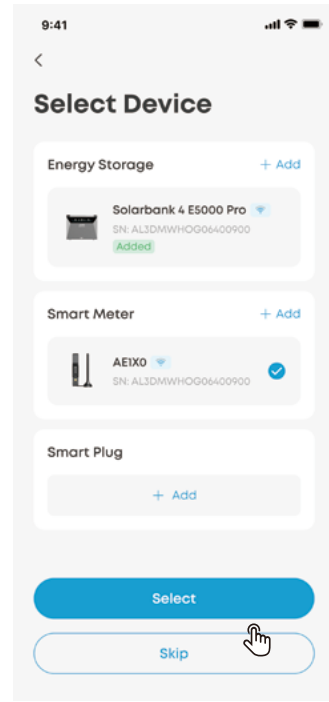
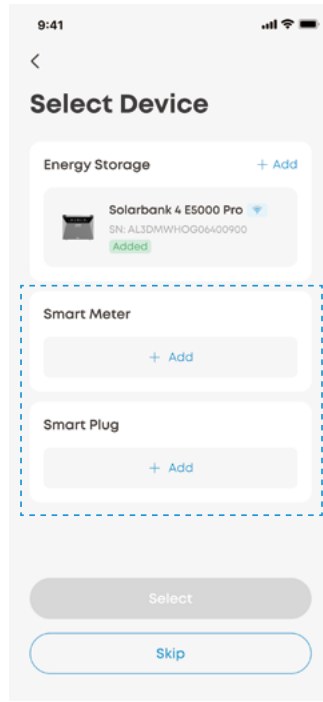
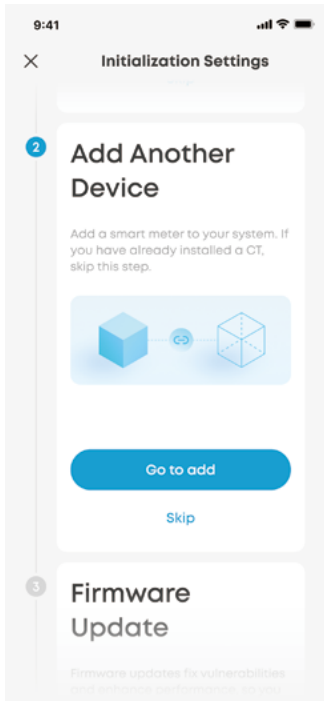

Firmware Update

Upgrade the firmware to enjoy optimal performance.

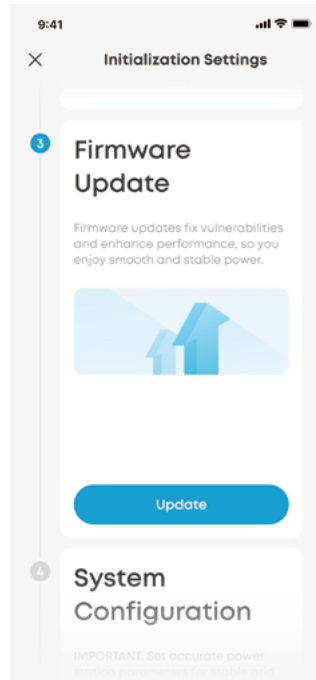

System Configuration

- ① Tap Settings to configure the power station parameters.
- ② Select your region to match the local grid code.
- ③ Select whether a third-party PV system is installed in your home.
- ④ (Optional) If a smart meter is installed, select whether the CT (PV / ESS) has been connected to the third-party PV system.

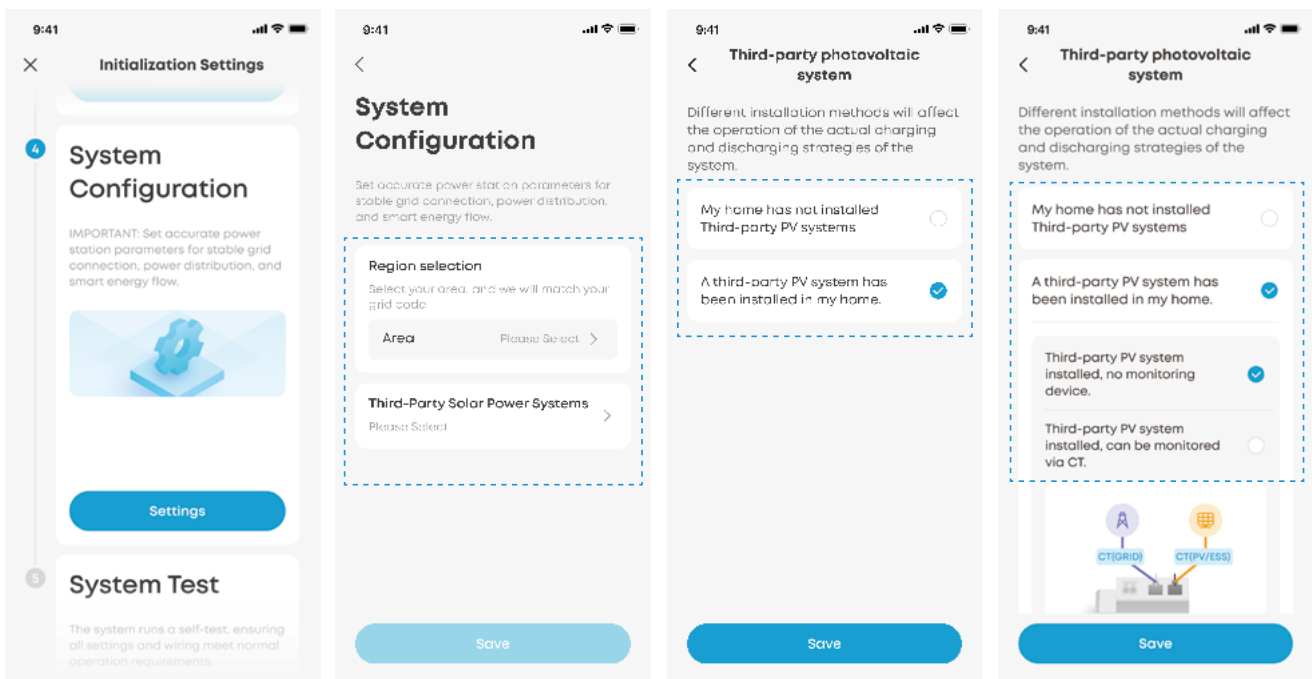

System Self-Test

- ① Tap Run Self-Test —Start Self-Check to perform the system test.
- ② The process will take a few minutes. Once complete, proceed to the next step.

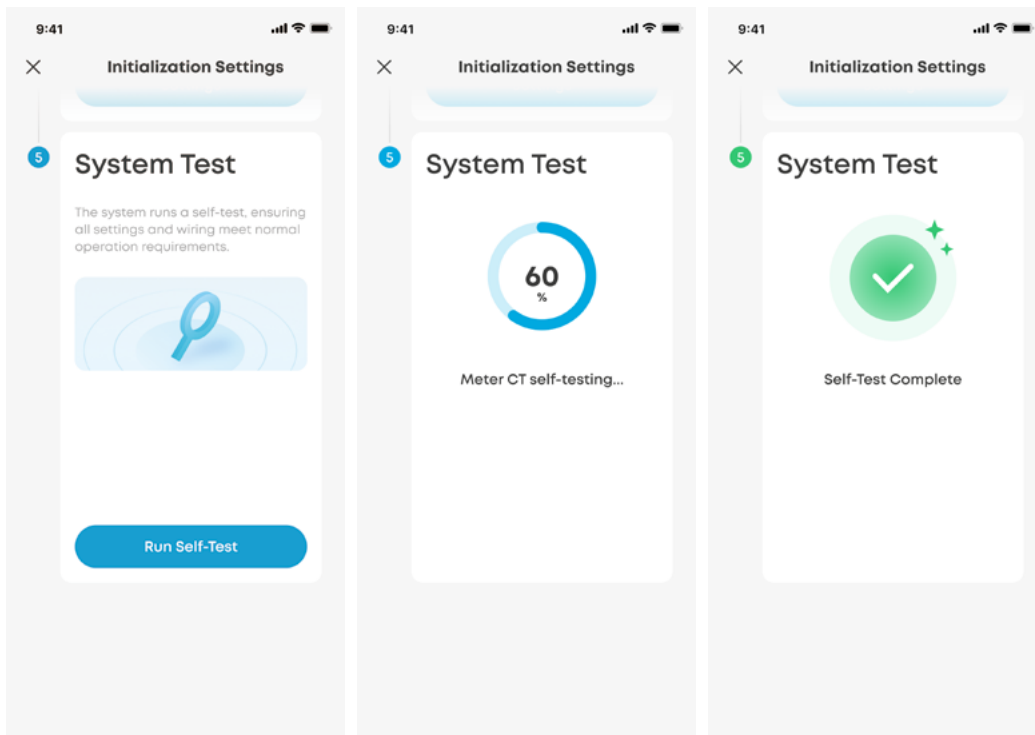

Perform Italy Self-Test (Italy only)

1. Go to **Settings - Advanced Settings - Italy Self-Test**.
2. If system testing is successful, tap Done to proceed.

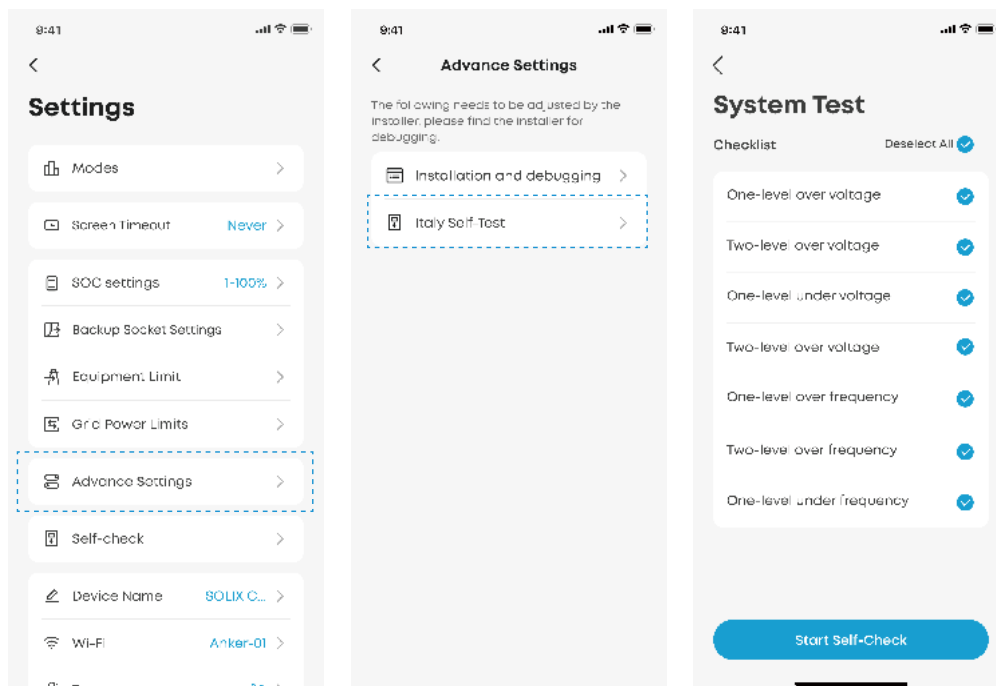

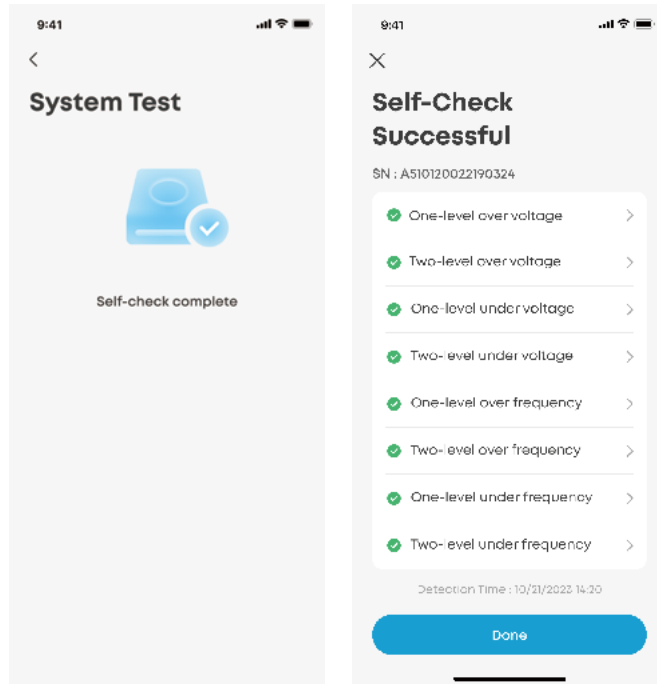

Customize Power Mode

Choose how your Solarbank manages power through the following modes to meet your home's energy needs

Access Mode Selection

During Setup: Select a power mode from the options provided.



After Setup: Access mode selection from the shortcut on the home page.

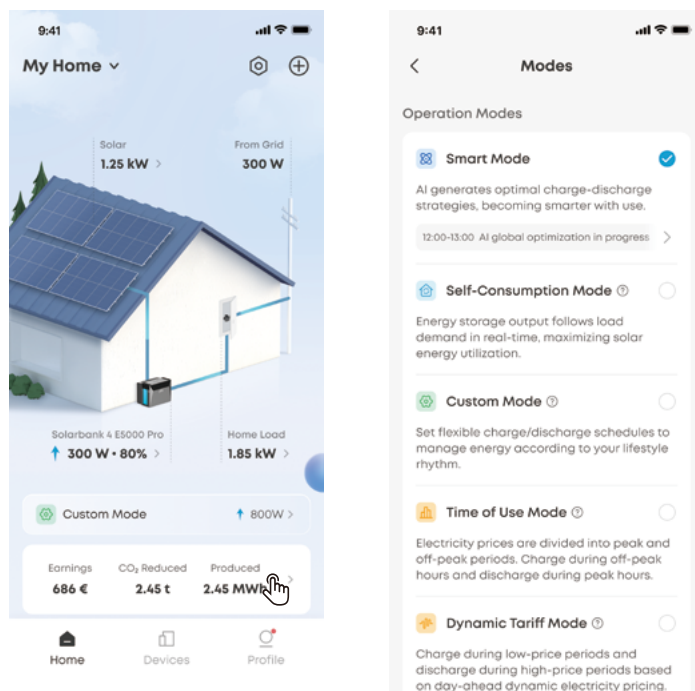

Smart Mode

In smart mode, your Solarbank forecasts future electricity production and consumption, as well as electricity prices, to create an optimal power schedule.



Smart mode requires a smart meter and is only compatible with phones that support Google Maps.

How to Set Up:

1. Select **Smart Mode**.
2. Complete the following settings:
 - Authorize data access.
 - Authorize location access.
 - Set your utility rate plan.
 - (Optional) Add and set your power plug.
3. Solarbank will start self-learning, then operate in Smart Mode once learning is complete.

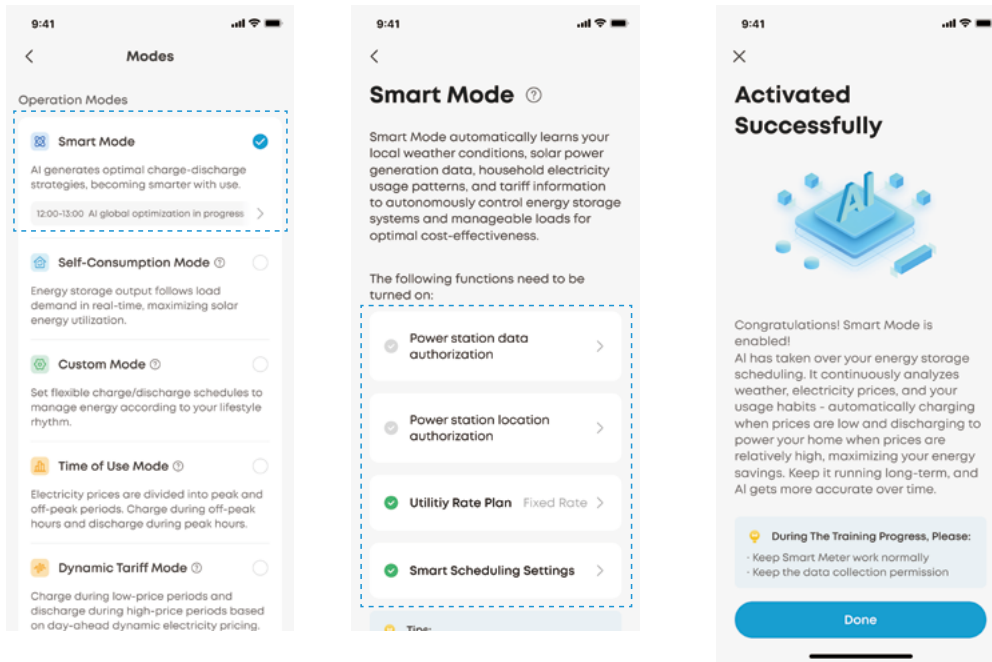

Self-Consumption Mode

Self-consumption mode maximizes your use of solar power and minimizes reliance on the grid. In this mode, the smart meter will continuously monitor power demand and Solarbank will dynamically adjust the power output or storage.



- Self-consumption mode requires a smart meter.
- If the smart meter goes offline or malfunctions, Solarbank will automatically switch to custom mode until the smart meter is functional again.

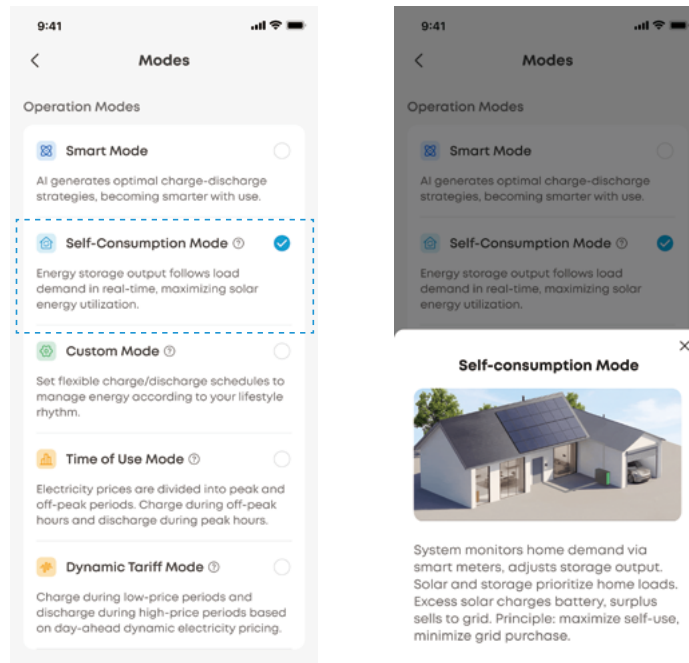

Custom Mode

Customize power output based on your specific needs throughout the day. In this mode, you can set a 24/7 schedule of photovoltaics consumption and storage for the Solarbank system. The system will power your home loads according to the schedule you set.

How to Set Up:

1. Select **Custom Mode**.
2. (Optional) If a Smart Plug is connected to your system, select whether to enable Smart socket independent scheduling.



Once enabled, the device will automatically calculate the discharge curve including Smart Plug power consumption and dispatch discharge accordingly.

3. Tap Add Schedule, then select the specific days of the week for plan execution.
4. Tap Set Plan to set discharge schedules for household loads.
5. Save and apply the energy plan.

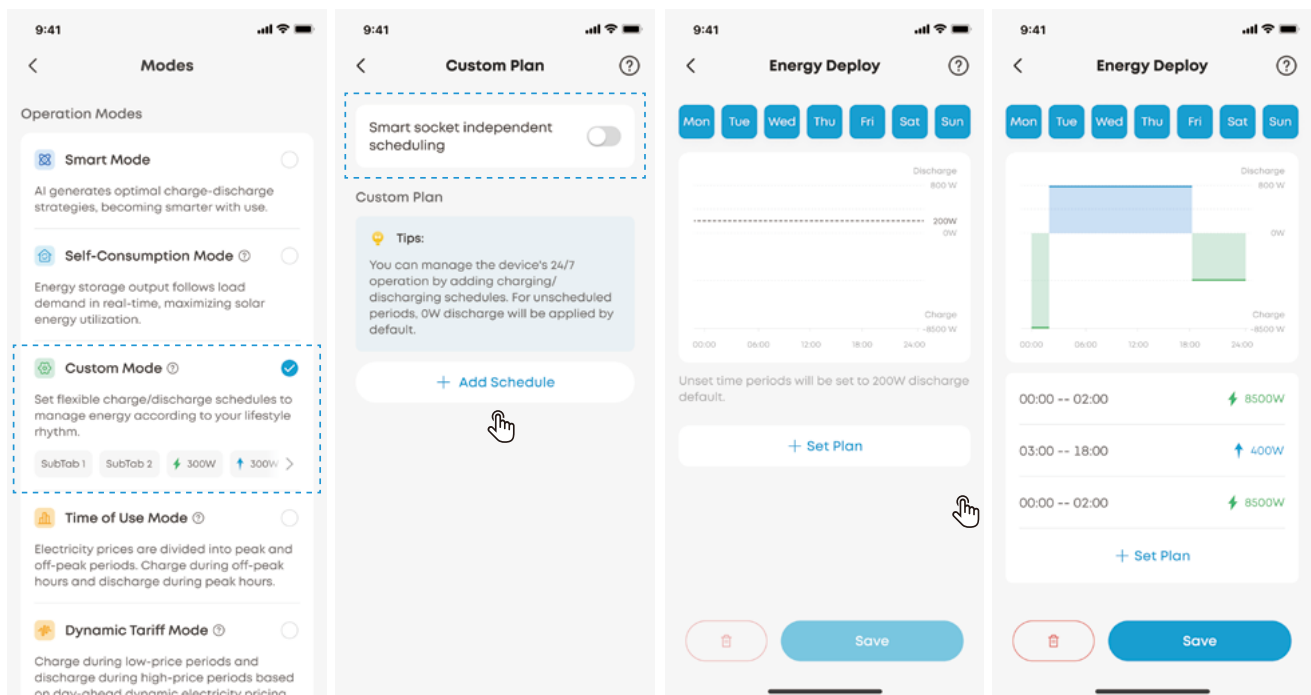

Time of Use Mode

Manually set the charge and discharge intervals to schedule energy use throughout the day. The periods are categorized as follows:

- **On-Peak / Mid-Peak:** Photovoltaic power prioritizes supplying the load. Excess photovoltaic power recharges energy storage. If photovoltaic power is insufficient for the load, energy storage will discharge and power will be purchased from the grid to meet demand.
- **Off-Peak:** Photovoltaic power prioritizes supplying the load. Excess electricity recharges energy storage. If photovoltaic power is insufficient, energy storage supplies power to the load until remaining power is approximately 80%.
- **Super Off-Peak:** Photovoltaic power prioritizes recharging energy storage. If power

generation is insufficient, electricity will be purchased from the grid. When energy storage is fully charged, the load will be powered by photovoltaic energy and grid electricity. Energy storage will not discharge at all during this time.

How to Set Up:

1. Select Time of Use Mode.
2. Select specific months for each season.
3. Tap Add Time Period
4. Edit time periods by dragging the slider. Tap Add Period to include additional periods. Repeat this for weekends if necessary.
5. Enter the rate pricing. Set unique "buy" and "sell" prices for each time period.
6. Repeat steps 4 and 5 for all time periods and seasons.
7. Review and save your settings.

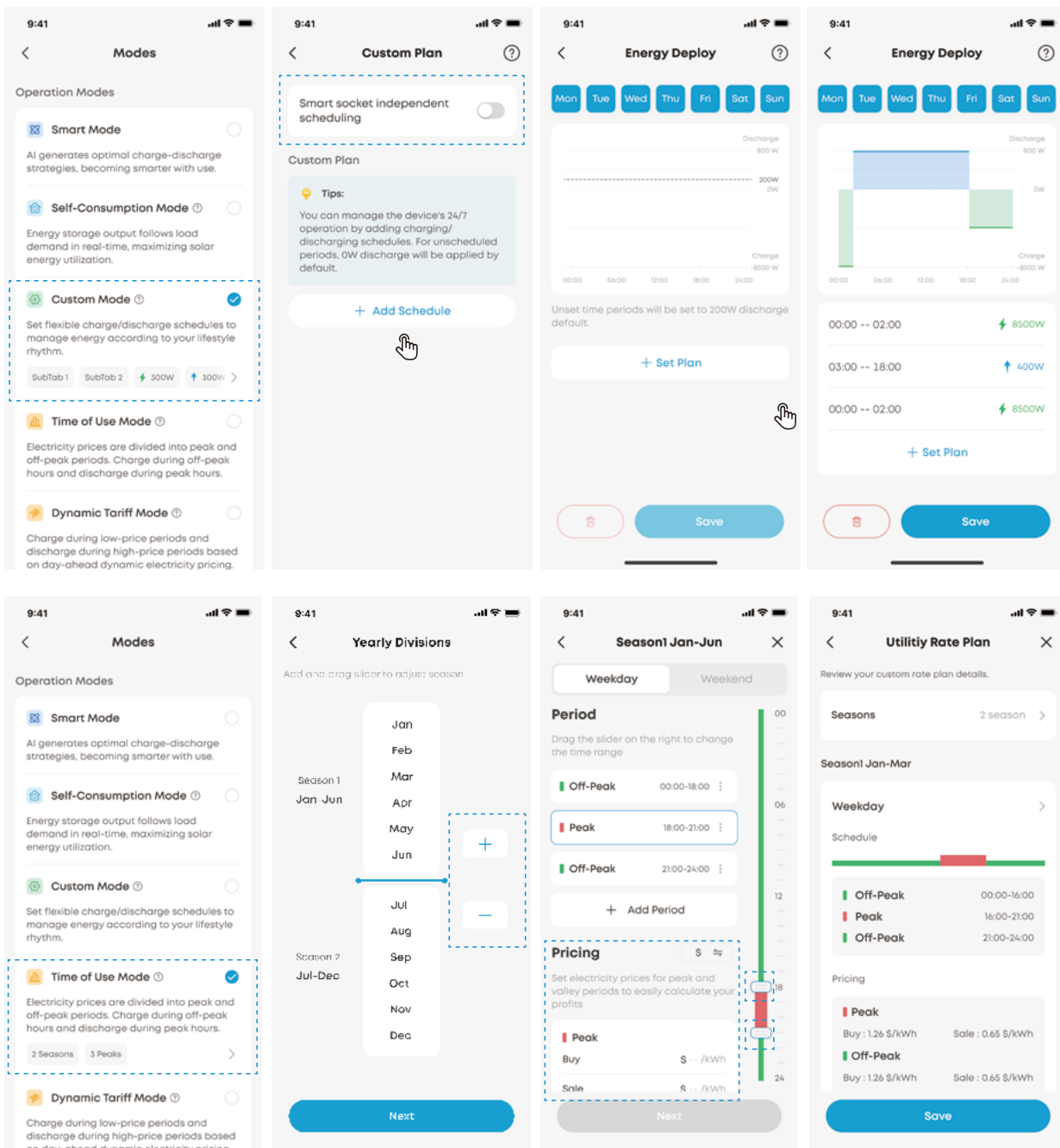

Dynamic Tariff Mode

1. Select Dynamic Tariff Mode.
2. (Optional) If the electricity rate has not been set, set it first.
3. Check tariff settings and make adjustments as needed. The system determines the optimal charging and discharging time slots based on the electricity prices and your settings.

Charging and Discharging Period Edit different time periods by dragging the slider.

- **SOC Cutoff:** The system automatically stops charging when the battery reaches cutoff power.
- **Charging Operation Times:** The system will identify the corresponding periods with lowest electricity prices based on your settings, and then automatically charge the battery during those periods.
- **Discharging Operation Times:** The system will identify the corresponding periods with highest electricity prices based on your settings, and then automatically discharge the battery during those periods.
- **Battery Export to Grid:** Enable this feature to feed excess energy to the grid. If this feature is disabled, the energy will be reserved for home use.

Charging Settings

Discharging Settings

Charging and Discharging Available Period

You can set the time period for charging and discharging. During the time period, the system will execute the EMS schedule according to the charging operation times and discharging operation times set below.

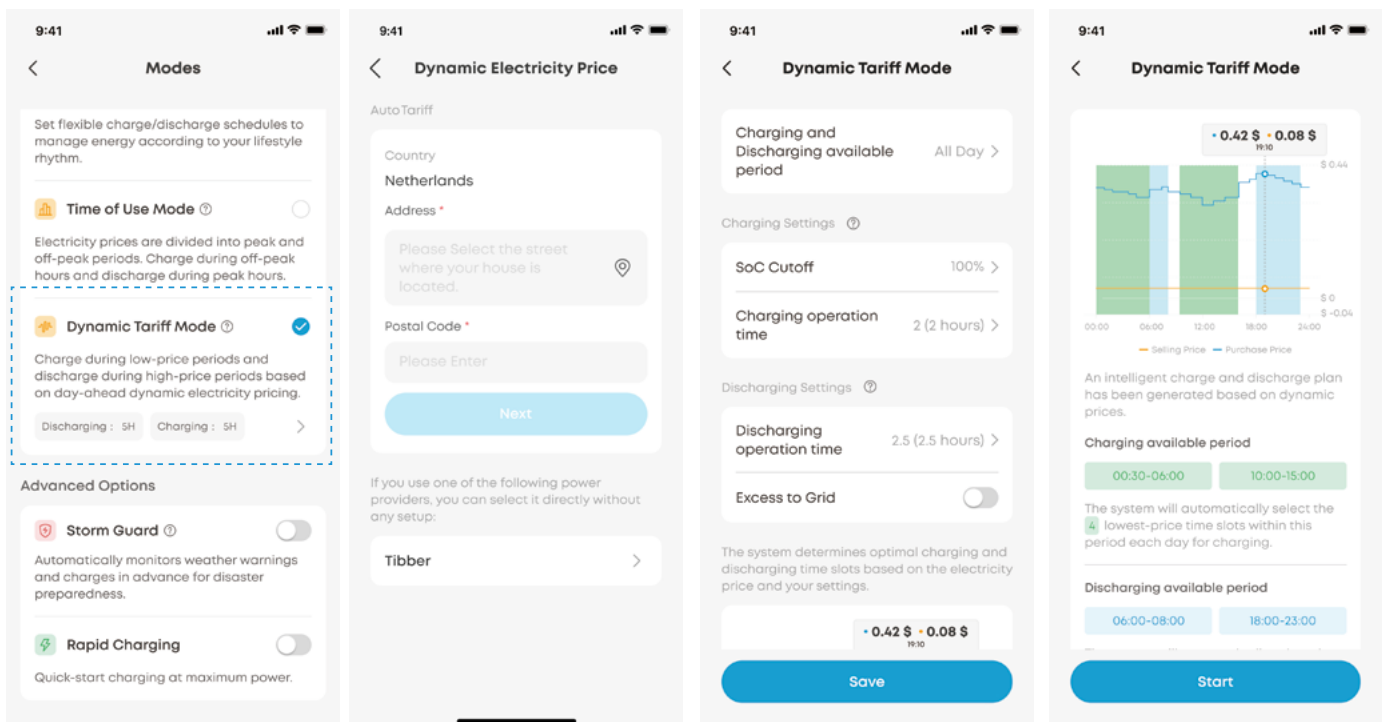

Storm Guard Mode

In this mode, the system automatically switches to backup power during a disaster and restores the previous strategy when the backup period ends.

How to Set Up:

1. Toggle on Storm Guard Mode.
2. Authorize location access.

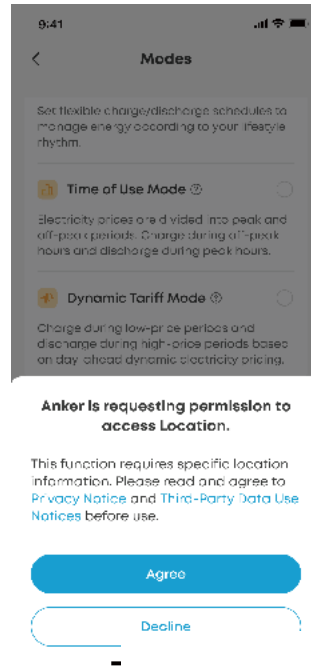
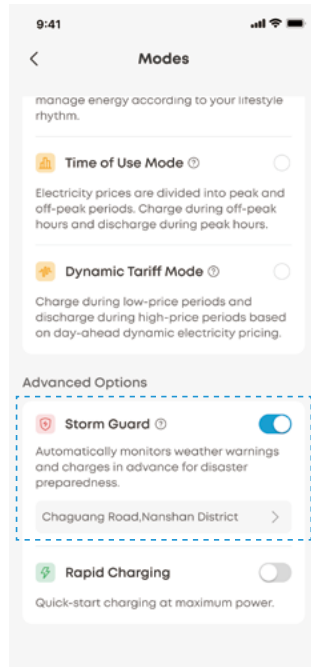

Rapid Charging

When Rapid Charging is enabled, Solarbank prioritizes battery charging in case of storm warnings or potential outages. You can set the start and end time for this change.

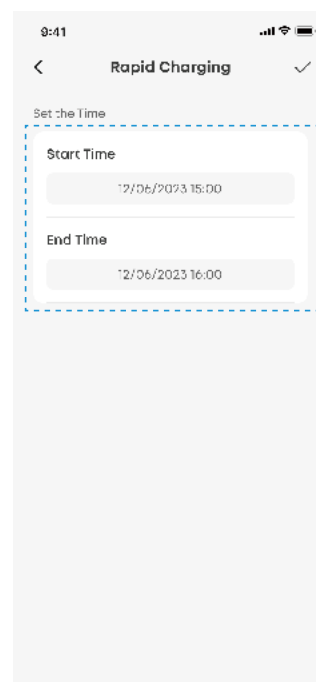
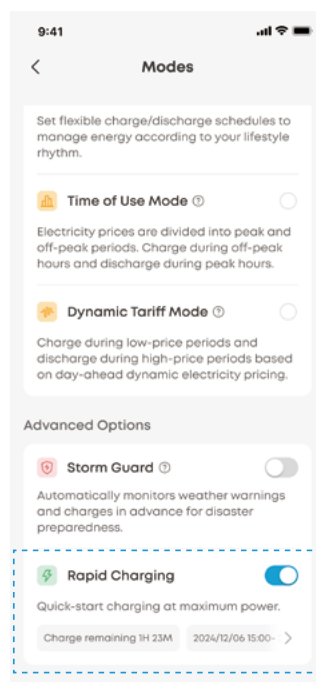

Specifications

Specifications are subject to change without notice.

Anker SOLIX Solarbank 4 E5000 Pro

Model	AE103SZ1, AE1038Z1, AE1033Z1-20, AE1033Z1
PV Terminal	
Max PV Input Voltage	60 VDC
Max PV Input Current	36 ADC ×4
Max Isc PV	45 ADC ×4
Max PV Input Power	1,250x 4 / 5000 W
Operation Voltage Range	16-50 VDC
Battery Data	
Rechargeable Li-ion Battery	LiFePO4 / LFP
Battery Nominal Voltage	16 VDC
Max Charge Current	180 ADC
Max Discharge Current	180 ADC
Rated Power (Single Device)	2,500 W
Rated Energy	5,024 Wh
Rated Capacity	314 Ah
AC Input (On-Grid Terminal)	
Max AC Input Power	3,600 W
Max AC Input Current	16 AAC
Max AC Charge Power	2,500W
Max AC Charge Current	10.9 AAC
AC Nominal Input Voltage	L+N+PE 220 Va.c./230 Va.c./240 Va.c., 50 Hz
AC Output (On-Grid Terminal)	
AC Output Power	600/790/800/2,500W
Max AC Apparent Power	600/790/800/2,500VA
Max AC Output Current	2.6/3.4/3.5/10.9AAC
Rated AC Output Power	600/790/800/2,500W
Rated AC Apparent Power	600/790/800/2,500VA
Rated AC Output Current	2.6/3.4/3.5/10.9 AAC
AC Nominal Output Voltage	L+N+PE 220 Va.c./230 Va.c./240 Va.c., 50 Hz
Power Factor Range	0.8 Lagging - 0.8 Leading

AC Output (Off-Grid Terminal)

Max AC Output Power	2,500 W
Max AC Output Current	10.9 AAC
Max AC Bypass Output Power	3,600 W
Max AC Bypass Output Current	16 AAC
AC Nominal Output Voltage	L+N+PE 220 Va.c./230 Va.c./240 Va.c., 50 Hz

Protection

Overvoltage Protection	Yes
Undervoltage Protection	Yes
Overcurrent Protection	Yes
Short Circuit Protection	Yes
Overheating Protection	Yes
Overcharge Protection	Yes
Overdischarge Protection	Yes
Islanding Detection	Yes
Insulation Impedance Detection	Yes
Surge Protection	Yes

General Parameters

Dimensions (L×H×D)	460×305×355mm
Weight	50 kg
Protective Class	Class I
Ingress Protection	IP66
Inverter Topology	Isolated
Wireless Type	Bluetooth, Wi-Fi (2.4 GHz)
Operating Temperature Range	-20 to 55
Max Altitude	4,000 m
Warranty	10 Years
Product Lifespan	15 Years

Anker SOLIX BP5000 Expansion Battery

PV Terminal

Battery Type	LiFePO ₄ / LFP
Battery Nominal Voltage	16 VDC
Max Charge Current	180 ADC
Max Discharge Current	180 ADC
Rated Power (Single Device)	2,500 W
Rated Energy	5,024 Wh
Rated Capacity	314Ah

General Parameters

Dimensions (L×H×D)	460×254×332.5mm
Weight	42 kg
Warranty	10 Years
Product Lifespan	15 Years
Protective Class	Class I
Ingress Protection	IP66
Operating Temperature Range	-20 to 55 °C
Max Altitude	4,000 m

Network Configuration Instructions

Bluetooth Low Energy (BLE) Status: When the equipment is not yet connected to a network, it will automatically enable BLE broadcasting and activate BLE services to provide Bluetooth network configuration capabilities.

Note: During the BLE configuration process, ensure your network environment is stable and follow the instructions to complete the setup.

Port 5353

The primary function of port 5353 (TCP/UDP 5353) in a network is to implement the mDNS protocol for mutual discovery between devices on the local area network (LAN).

Application Scenarios: Multi-device linkage, self-consumption scenarios, and energy scheduling strategies in the LAN.

Access the device via hostname.local on the same local area network without traditional DNS configuration.

mDNS Protocol Characteristics: Using UDP protocol, port 5353 is its standard port, compatible with the standard DNS query format.