

## Test Report

Client : Anker Solix Innovations Limited  
 Flat/RM 829, 8/F, Tower 2, Admiralty Centre, 18 Harcourt Road, Hong Kong

Sample Description : Anker Solix Solarbank 4 E5000 Pro  
 Type(s) : AE103SZ1, AE1038Z1, AE1033Z1-20, AE1033Z1, AE1032Z1-20, AE1032Z1, AE1033Z1-85

Factory : Huizhou Blueway Electronics Co., Ltd.  
 101, West Hechang 5th Road Zhongkai High-Tech Development Zone  
 516006 Huizhou, Guangdong China  
 Luxshare Energy (Jiangxi) Co., Ltd.  
 No.1, Shuguang Road, West Zone of Industrial Park, Ji'an County, Ji'an City, Jiangxi, China

The information and sample(s) above were submitted and identified by or on behalf of the client.

Sample Received : 2026-02-09, 2026-04-02, 2026-04-16

Testing Period : 2026-02-09 to 2026-04-16

<b><u>Test Requested</u></b>		<b><u>Result</u></b>
1.	Directive 2012/19/EU of the European Parliament and of the council of 4 July 2012 on waste electrical and electronic equipment (WEEE) and its Amendment directive.	
	- Reuse/Recycling and Recovery Assessment	PASS
2.	EN 50419:2022-Marking of electrical and electronic equipment in accordance with article 15 (2) of Directive 2012/19/EU (WEEE)	PASS

Signed for and on behalf of

**DEKRA Testing and Certification (Shanghai) Ltd., Guangzhou branch**



Devin Ai

Approver

## TEST RESULTS

### 1. Reuse/Recycling and Recovery Assessment.

#### a. General Information

##### Sample 1:

**Sample Weight** : 49750.00g  
**Category Under the WEEE** : 5<sup>th</sup> Category (Small equipment (no external dimension more than 50 cm))  
**Directive**  
**Product Size (w\*d\*h)** : 460\*345\*306mm

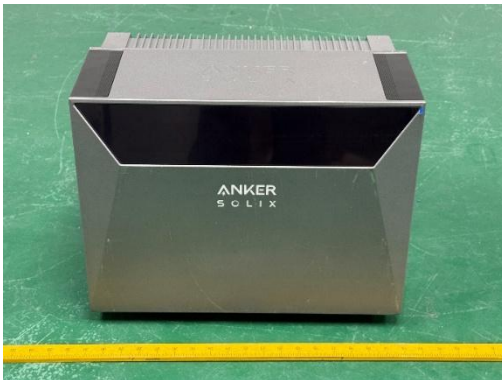

##### Sample 2:

**Sample Weight** : 50102.00g  
**Category Under the WEEE** : 5<sup>th</sup> Category (Small equipment (no external dimension more than 50 cm))  
**Directive**  
**Product Size (w\*d\*h)** : 460\*254\*332.5mm



**b. Result of Reuse/Recycling and Recovery Assessment**

Reuse/Recycling/Recovery	Reuse/Recycling/Recovery Targets Under the 2012/19/EU WEEE Directive	Result of Assessment	Conclusion(s)
		Sample 1	
Reuse/Recycling (%)	55 Min.	83.91	PASS
Recovery (%)	75 Min.	85.66	PASS

Reuse/Recycling/Recovery	Reuse/Recycling/Recovery Targets Under the 2012/19/EU WEEE Directive	Result of Assessment	Conclusion(s)
		Sample 2	
Reuse/Recycling (%)	55 Min.	83.73	PASS
Recovery (%)	75 Min.	86.06	PASS

**c. Appearance of the Product**

**Sample 1:**



*Above*



*Bottom*



*Front*



*Rear*



*Left*



*Right*

Sample 2:



*Above*



*Bottom*



*Front*



*Rear*



*Left*



*Right*

**d. Selective Treatment for Materials and Components**

**Sample 1:**

According to articles 6(1) and the Annex II of the WEEE Directive, this product contains components and material items are described in the following table.			
Component/Material	Photo No.	Size & quantity	Weight (g)
Battery	B12	--	27500.00
PCB	B11	1896.33CM <sup>2</sup>	4450.00

**Sample 2:**



According to articles 6(1) and the Annex II of the WEEE Directive, this product contains components and material items are described in the following table.			
Component/Material	Photo No.	Size & quantity	Weight (g)
Battery	D12	--	27750.00
PCB	D11	1896.33CM <sup>2</sup>	4450.00

**e. Disassembly Procedure**

The disassembly procedure taken here is in accordance with the treatment requirements under the Annex II of the WEEE Directive. In addition, to consider economic and efficiency factors, manual operation and disassembly tools have been applied to separate the components and materials from this product in order to simulate the scenario at the treatment facility, and to achieve the objective that the separated components and materials can be reused, recycled and recovered.

**i) Disassembly tool**

The disassembly tools used for this product show as following:

Disassembly Tool	Picture	Disassembly Tool	Picture
Screwdriver		Diagonal Pliers	
Pruning Shears		---	---

ii) Disassembly time

240Minutes

f. Disassembly Tree

Sample 1:

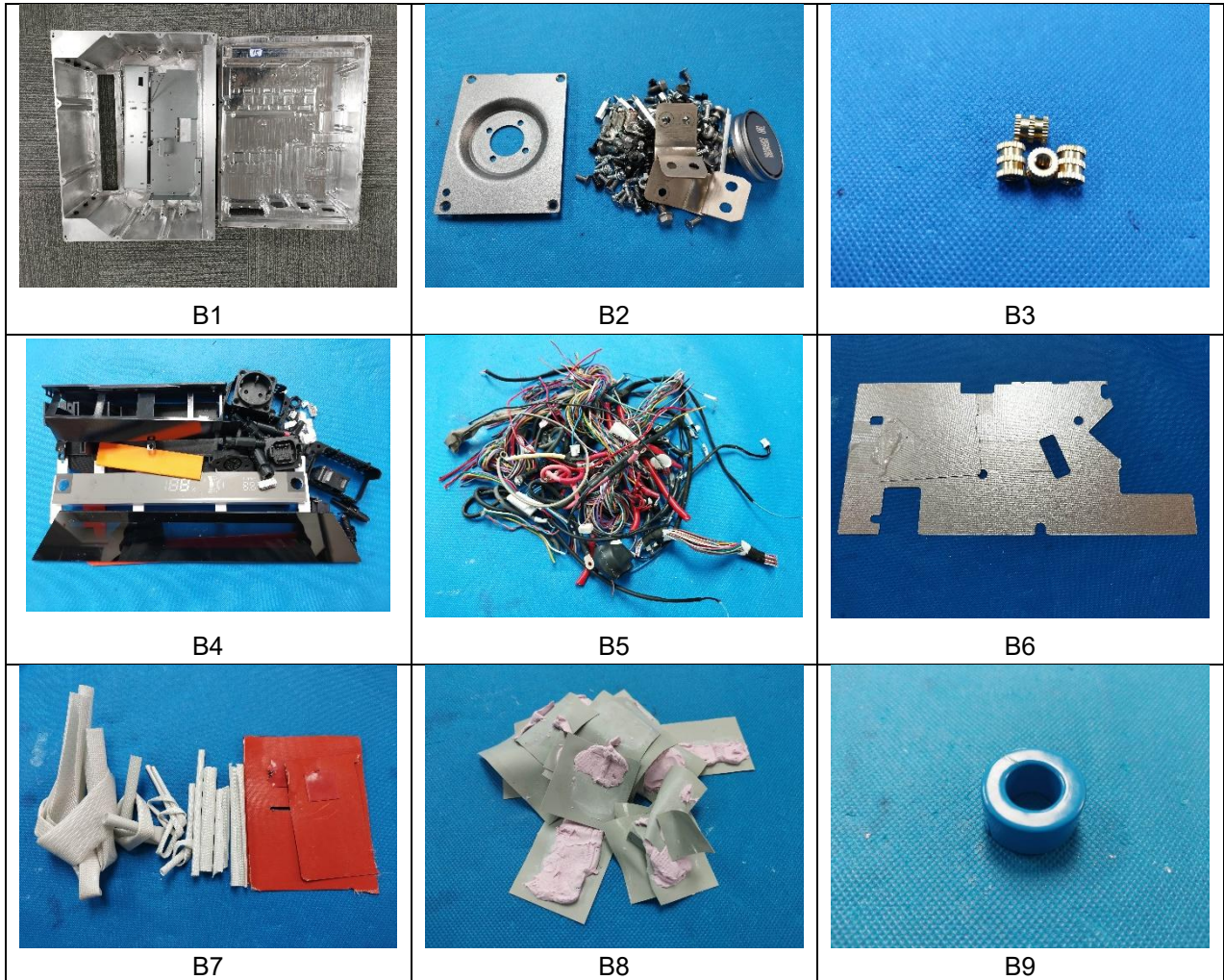

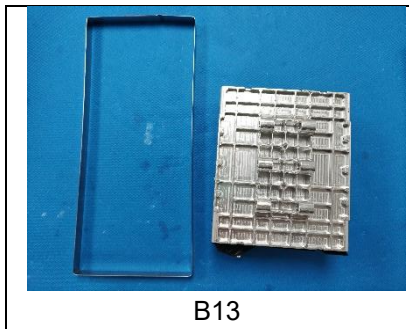
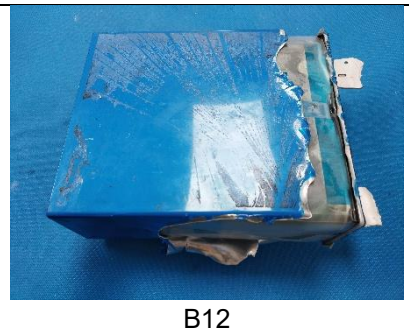
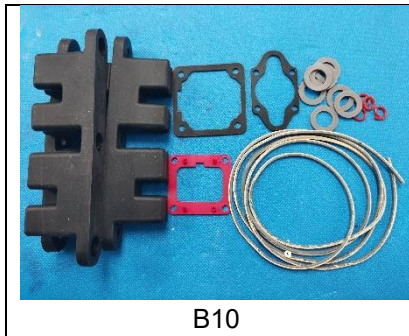

**Sample 2:**

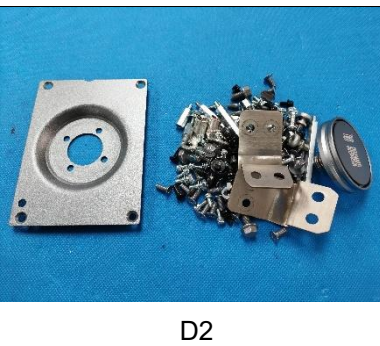
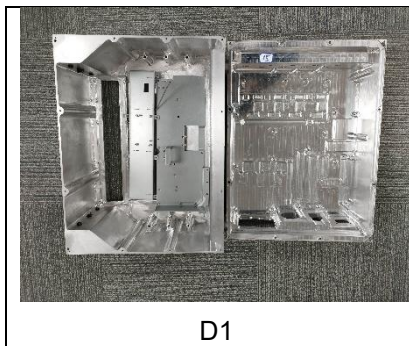



**g. Loss during disassembly**

Test sample	Sample 1	Sample 2
Product weight before disassembly	49750.00g	50102.00g
Product weight after disassembly	49235.34g	49485.34g
Lost Rate	1.03%	1.23%

**h. Material and Recycling Information**

According to the information declared by the applicant company, the material and recycling information for this product is described in the following table. There use, recycling and recovery assessment for this product is based upon economic and efficiency considerations, and the waste treatment technologies and equipment that are most frequently available to the market.

**Sample 1:**

Material	Photo No.	Weight (g)	Weight percentage (%)	Reuse/ Recycling Rate (%)	Energy Recovery Rate (%)	Recovery Rate (%)
Metal	B1	12600.00	25.33	24.82	0.00	24.82
Metal	B2	249.34	0.50	0.49	0.00	0.49
Copper	B3	5.73	0.01	0.01	0.00	0.01
Plastic	B4	712.00	1.43	1.26	0.00	1.26
Copper+PVC	B5	308.40	0.62	0.25	0.11	0.36
Mica sheet	B6	53.39	0.11	0.09	0.00	0.09
Fabric	B7	118.32	0.24	0.00	0.21	0.21
Silicone grease	B8	130.23	0.26	0.00	0.24	0.24
Ceramic	B9	44.97	0.09	0.09	0.00	0.09
Rubber	B10	212.96	0.43	0.00	0.39	0.39
PCB	B11	4450.00	8.94	8.05	0.00	8.05
Battery	B12	27500.00	55.28	44.22	0.00	44.22
Metal	B13	1900.00	3.82	3.74	0.00	3.74
Foam	B14	444.96	0.89	0.00	0.80	0.80
plastic	B15	505.04	1.02	0.89	0.00	0.89
Total		49235.34	98.97	83.91	1.75	85.66

Sample 2:

Material	Photo No.	Weight (g)	Weight percentage (%)	Reuse/ Recycling Rate (%)	Energy Recovery Rate (%)	Recovery Rate (%)
Metal	D1	12600.00	25.15	24.65	0.00	24.65
Metal	D2	249.34	0.50	0.49	0.00	0.49
Copper	D3	5.73	0.01	0.01	0.00	0.01
Plastic	D4	712.00	1.42	1.25	0.00	1.25
Copper+PVC	D5	308.40	0.62	0.25	0.11	0.36
Mica sheet	D6	53.39	0.11	0.09	0.00	0.09
Fabric	D7	118.32	0.24	0.00	0.21	0.21
Silicone grease	D8	130.23	0.26	0.00	0.23	0.23
Ceramic	D9	44.97	0.09	0.09	0.00	0.09
Rubber	D10	212.96	0.43	0.00	0.38	0.38
PCB	D11	4450.00	8.88	7.99	0.00	7.99
Battery	D12	27750.00	55.39	44.31	0.00	44.31
Metal	D13	1900.00	3.79	3.72	0.00	3.72
Foam	D14	444.96	0.89	0.00	0.80	0.80
plastic	D15	505.04	1.01	0.89	0.00	0.89
Total		49485.34	98.77	83.73	1.74	86.06

**i. Recycling and Recovery Rate Calculation**

Recycling & recovery rate using in the report are calculated as following formulas:

$$\text{Reuse/Recycling Rate} = \frac{\text{Reuse/Recycling Weight}}{\text{Product Total Weight}} (\%)$$

$$\text{Recovery Rate} = \frac{\text{Reuse/Recycling Weight} + \text{Energy Recovery Weight}}{\text{Product Total Weight}} (\%)$$

**j. ANNEX VII of WEEE Directive**

Selective treatment for materials and components of waste electrical and electronic equipment:

- Polychlorinated biphenyls (PCB) containing capacitors in accordance with council directive 96/59/EC of 16 September 1996 on the disposal of polychlorinated biphenyls and polychlorinated terphenyls (PCB/PCT) (1).
- Mercury containing components, such as switches or backlighting lamps.
- Batteries.
- Printed circuit boards of mobile phones generally, and of other devices if the surface of the printed circuit board is greater than 10 square centimeters.
- Toner cartridges, liquid and pasty, as well as colour toner.
- Plastic containing brominated flame retardants.
- Asbestos waste and components which contain asbestos.
- Cathode ray tubes.
- Chlorofluorocarbons (CFC), hydrochlorofluorocarbons (HCFC) or hydrofluorocarbons(HFC), hydrocarbons (HC).
- Gas discharge lamps.
- Liquid crystal displays (together with their casing where appropriate) of a surface greater than 100 square centimeters and all those back-lighted with gas discharge lamps.
- External electric cables.
- Components containing refractory ceramic fibres as described in commission directive 97/69/EC of 5 December 1997 adapting to technical progress council directive 67/548/EEC relating to the classification, packaging and labelling of dangerous substances.
- Components containing radioactive substances with the exception of components that are below the exemption thresholds set in article 3 of and Annex I to council directive 96/29/ Euratom of 13 May 1996 laying down basic safety standards for the protection of the health of workers and the general public against the dangers arising from ionizing radiation.
- Electrolyte capacitors containing substances of concern (height > 25 mm, diameter > 25 mm or proportionately similar volume).

**k. Recommendations for WEEE Directive Compliance**

- In order to avoid the product not meeting the reuse/recycling/recovery targets regulated under the WEEE directive and the regulations of EU countries, the applicant company should, when selecting material and the impact of the required international environmental directives and also improve the product's competitiveness.
- It is recommended that the applicant company, when designing new product, especially where components and materials have a large weight ratio, should consider recyclable materials in order to increase the product's reuse/recycling/recover ratio.
- The product should apply to the RoHS Directive (Directive 2011/65/EU on the restriction of the use of certain hazardous substances in electrical and electronics equipment). The hazardous substance specification in the directive should be controlled in the homogenous material of this product.
- If a product has changed its product design, or materials or components employed, then the product should be reassessed and retested in accordance with the WEEE Directive for reuse/recycling/recovery assessment and RoHS for restricted/banned substances requirements.

## I. Categories of EEE product

- 1 Temperature exchange equipment
- 2 Screens, monitors, and equipment containing screens having a surface greater than 100 cm<sup>2</sup>
- 3 Lamps
- 4 Large equipment (any external dimension more than 50 cm) including, but not limited to:  
Household appliances; IT and telecommunication equipment; consumer equipment; luminaires; equipment reproducing sound or images, musical equipment; electrical and electronic tools; toys, leisure and sports equipment; medical devices; monitoring and control instruments; automatic dispensers; equipment for the generation of electric currents. This category does not include equipment included in categories 1 to 3.
- 5 Small equipment (no external dimension more than 50 cm) including, but not limited to:  
Household appliances; consumer equipment; luminaires; equipment reproducing sound or images, musical equipment; electrical and electronic tools; toys, leisure and sports equipment; medical devices; monitoring and control instruments; automatic dispensers; equipment for the generation of electric currents. This category does not include equipment included in categories 1 to 3 and 6.
- 6 Small IT and telecommunication equipment (no external dimension more than 50 cm)

## m. Minimum Recovery Targets Referred

Minimum targets applicable by category from 15 August 2018 with reference to the categories listed in Annex III:

- (a) for WEEE falling within category 1 or 4 of Annex III,
  - 85 % shall be recovered, and
  - 80 % shall be prepared for re-use and recycled;
- (b) for WEEE falling within category 2 of Annex III,
  - 80 % shall be recovered, and
  - 70 % shall be prepared for re-use and recycled;
- (c) for WEEE falling within category 5 or 6 of Annex III,
  - 75 % shall be recovered, and
  - 55 % shall be prepared for re-use and recycled;
- (d) for WEEE falling within category 3 of Annex III, 80 % shall be recycled.

## 2. **EN 50419:2022-Marking of electrical and electronic equipment in accordance with article 15 (2) of Directive 2012/19/EU (WEEE)**

### **Marking of electrical and electronic equipment**

As per article 15 (2) of Directive 2012/19/EU (WEEE) and marking requirement in article 7(c), 7(g), 7(h) and European Standard EN 50419:2022 on marking of electrical and electronic equipment.

a) The following markings shall be applied on the product.

1) Unique identification of the producer

**Result:** Producer can be identified on the product and packaging.

2) Marking as shown in Figure 1

**Result:** see details as in below table

*Crossed-out wheeled bin symbol with solid bar*

Parameters	Finding	
Location	Printed on product of the sample	Only packaging artwork of the sample submitted
Structure of symbol ((refer to Figure 1)	Identical	Identical
Total height of the symbol combination ( $\geq 7\text{mm}$ )	8.0mm	7.2mm
Height of solid bar ( $>0.3a$ or 1mm)	1.2mm	1.0mm
Width of the solid bar	4.6mm	4.2mm
Width of the bin	3.4mm	2.8mm
Total height of the bin	4.6mm	4.2mm
Height of the bin not include cover and wheel	3.6mm	3.4mm
Height of the cross	6.0mm	5.0mm
Distance from base of solid bar to base of cross	2.0mm	2.2mm
Dimensional relationship (refer to Figure 1)	Visual appearance is maintained	Visual appearance is maintained
Durability (shall be legible after rubbing)	No change after rubbing test	Only packaging artwork of the sample submitted

b) Marking shall be visible, legible and indelible

**Result:** The marking on the product is visible, legible and indelible.

**Conclusion:**

The submitted samples are compliance with the requirements of EN 50419:2022.

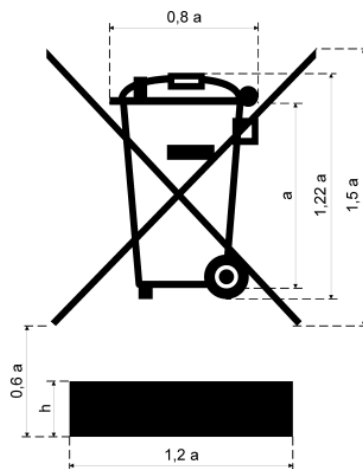

**Figure 1**

**---End of Report---**

This document is issued subject to the company's General Terms and Conditions available at <https://www.dekra.com.cn/en/terms-and-conditions/>. Unless otherwise stated, the test results refer exclusively to the samples tested in this report. Statements of conformity are based on simple acceptance criteria without taking measurement uncertainty into consideration. DEKRA declines any responsibility with information provided and/or deviations required by the client that may affect the validity of test results. This report can only be reproduced in full and with written approval of the test laboratory. If you have any comment on the test results, please contact us in writing within 15 days after the issuance of this report. The test results shall not be used for propaganda without permission of the test laboratory. This report is not to be used for social proof function in China market.